

### Models:

TRUE-36C    TRUE-50C  
TRUE-36H    TRUE-50H  
TRUE-36S    TRUE-50S  
TRUE-42C  
TRUE-42H  
TRUE-42S

GAS-FIRED



### NOTICE



#### DO NOT DISCARD THIS MANUAL

- Important operating and maintenance instructions included.
- Read, understand and follow these instructions for safe installation and operation.
- Leave this manual with party responsible for use and operation.

**⚠ WARNING:** If the information in these instructions is not followed exactly, a fire or explosion may result causing property damage, personal injury, or death.

- **DO NOT** store or use gasoline or other flammable vapors and liquids in the vicinity of this or any other appliance.
- **What to do if you smell gas**
  - **DO NOT** try to light any appliance.
  - **DO NOT** touch any electrical switch. **DO NOT** use any phone in your building.
  - Immediately call your gas supplier from a neighbor's phone. Follow the gas supplier's instructions.
  - If you cannot reach your gas supplier, call the fire department.
- Installation and service must be performed by a qualified installer, service agency, or the gas supplier.

This appliance may be installed as an OEM installation in manufactured home (USA only) or mobile home and must be installed in accordance with the manufacturer's instructions and the manufactured home construction and safety standard, *Title 24 CFR, Part 3280* or *Standard for Installation in Mobile Homes, CAN/CSA Z240MH*, in Canada.

*This appliance is only for use with the type(s) of gas indicated on the rating plate.*

### ⚠ WARNING



#### HOT SURFACES!

Glass and other surfaces are hot during operation AND cool down.

#### Hot glass will cause burns.

- **DO NOT** touch glass until it is cooled
  - NEVER allow children to touch glass
  - Keep children away
  - CAREFULLY SUPERVISE children in same room as fireplace.
  - Alert children and adults to hazards of high temperatures.
- High temperatures may ignite clothing or other flammable materials.**
- Keep clothing, furniture, draperies and other flammable materials away.

***This appliance has been supplied with an integral barrier to prevent direct contact with the fixed glass panel. DO NOT operate the appliance with the barrier removed.***

Contact your dealer or Hearth & Home Technologies if the barrier is not present or help is needed to properly install one.

In the Commonwealth of Massachusetts installation must be performed by a licensed plumber or gas fitter.

See Table of Contents for location of additional Commonwealth of Massachusetts requirements.



Installation and service of this appliance should be performed by qualified personnel. Hearth & Home Technologies suggests NFI certified or factory trained professionals, or technicians supervised by an NFI certified professional.

Read this manual before installing or operating this appliance.  
Please retain this owner's manual for future reference.

## A. Congratulations

Congratulations on selecting a Heat & Glo gas fireplace, an elegant and clean alternative to wood burning fireplaces. The Heat & Glo gas fireplace you have selected is designed to provide the utmost in safety, reliability, and efficiency.

As the owner of a new fireplace, you'll want to read and carefully follow all of the instructions contained in this owner's manual. Pay special attention to all cautions and warnings.

This owner's manual should be retained for future reference. We suggest that you keep it with your other important documents and product manuals.

The information contained in this owner's manual, unless noted otherwise, applies to all models and gas control systems.

Your new Heat & Glo gas fireplace will give you years of durable use and trouble-free enjoyment. Welcome to the Heat & Glo family of fireplace products!

<b>Homeowner Reference Information</b>	<i>We recommend that you record the following pertinent information about your fireplace.</i>
Model Name: _____	Date purchased/installed: _____
Serial Number: _____	Location on fireplace: _____
Dealership purchased from: _____	Dealer Phone: _____
Notes: _____	
_____	

## Listing Label Information/Location

The model information regarding your specific fireplace can be found on the rating plate usually located in the control area of the fireplace.

**HEAT & GLO**  
No one builds a better fire

Heat & Glo, a brand of Hearth & Home Technologies, Inc.  
7571 215th Street West, Lakeville, MN 55044

**GAS-FIRED**  
**UL LISTED**

Not for use with solid fuel.  
(Ne doit pas être utilisé avec un combustible solide).

Type of Gas (Sorte De Gaz): **NATURAL GAS** This appliance must be installed in accordance with local codes, if any; if not, follow ANSI Z223.1 in the USA or CAN/CGA B149 installation codes. (Installer l'appareil selon les codes ou règlements locaux ou, en l'absence de tels règlements, selon les codes d'installation CAN/CGA-B149.)

ANSI Z21XX-XXXX · CSA 2.XX-MXX · UL307B

Minimum Permissible Gas Supply for Purposes of Input Adjustment.

Approved Minimum (De Gaz) Acceptable	0.0 in w.c.	(Po. Col. d'eau)
Maximum Pressure (Pression)	0.0 in w.c.	(Po. Col. d'eau)
Maximum Manifold Pressure (Pression)	0.0 in w.c.	(Po. Col. d'eau)
Minimum Manifold Pressure (Pression)	0.0 in w.c.	(Po. Col. d'eau)

Total Electrical Requirements: 000Vac, 00Hz., less than 00 Amperes

**MADE IN USA**

ALTITUDE:	0-0000 FT.	IN CANADA	0000-0000FT.	Model:	XXXXXXXXXX
MAX. INPUT BTUH:	00,000		00,000	(Modele):	
MIN. INPUT BTUH:	00,000		00,000	Serial	XXXXXXXXXX
ORIFICE SIZE:	#XXXXXX		#XXXXXX	(Serie):	

Arrows from the diagram point to: Type of Gas, Gas and Electric Information, Model Number, and Serial Number.

## ▲ Safety Alert Key:

- **DANGER!** Indicates a hazardous situation which, if not avoided will result in death or serious injury.
- **WARNING!** Indicates a hazardous situation which, if not avoided could result in death or serious injury.
- **CAUTION!** Indicates a hazardous situation which, if not avoided, could result in minor or moderate injury.
- **NOTICE:** Used to address practices not related to personal injury.

## Table of Contents

A. Congratulations . . . . .	2
B. Limited Lifetime Warranty . . . . .	5

### 1 Listing and Code Approvals

A. Appliance Certification . . . . .	7
B. Glass Specifications . . . . .	7
C. BTU Specifications . . . . .	7
D. High Altitude Installations . . . . .	7
E. Non-Combustible Materials Specification . . . . .	7
F. Combustible Materials Specification . . . . .	7
G. Electrical Codes . . . . .	7
H. Requirements for the Commonwealth of Massachusetts . . . . .	8

## User Guide

### 2 Operating Instructions

A. Gas Fireplace Safety . . . . .	9
B. Your Fireplace . . . . .	9
C. Clear Space . . . . .	10
D. Decorative Doors and Fronts . . . . .	10
E. Fixed Glass Assembly . . . . .	10
F. Remote Controls, Wall Controls and Wall Switches . . . . .	10
G. IPI Battery Tray/Battery Installation . . . . .	10
H. Rating Plate/Glass Clip Tool Location . . . . .	10
I. Control Module Operation . . . . .	11
J. Before Lighting Fireplace . . . . .	11
K. Lighting Instructions (IPI) . . . . .	12
L. After Fireplace is Lit . . . . .	13
M. Frequently Asked Questions . . . . .	13

### 3 Maintenance and Service

A. Maintenance Tasks-Homeowner . . . . .	14
B. Maintenance Tasks-Qualified Service Technician . . . . .	15

## Installer Guide

### 4 Getting Started

A. Typical Appliance System . . . . .	17
B. Design and Installation Considerations . . . . .	18
C. Tools and Supplies Needed . . . . .	18
D. Inspect Appliance and Components . . . . .	18

### 5 Framing and Clearances

A. Selecting Appliance Location . . . . .	19
B. Constructing the Appliance Chase . . . . .	20
C. Clearances . . . . .	20
D. Mantel and Wall Projections . . . . .	21
→ E. Hearth Extension . . . . .	23

### 6 Termination Locations

A. Vent Termination Minimum Clearances . . . . .	24
--	----

### 7 Vent Information and Diagrams

A. Approved Pipe . . . . .	26
B. Vent Table Key . . . . .	26
C. Use of Elbows . . . . .	26
D. Measuring Standards . . . . .	26
E. Vent Diagrams . . . . .	26
F. PVK-80 and PVI-SLP Information . . . . .	33

### 8 Vent Clearances and Framing

A. Pipe Clearances to Combustibles . . . . .	34
B. Wall Penetration Framing . . . . .	34
C. Install the Ceiling Firestop . . . . .	35
D. Install Attic Insulation Shield . . . . .	36
E. Installing the Optional Heat-Zone® Gas Kit . . . . .	36

### 9 Appliance Preparation

A. Vent Preparation . . . . .	37
B. Securing and Leveling the Appliance . . . . .	38
C. Installing Non-combustible Facing Material . . . . .	39

### 10 Installing Vent Pipe (DVP Pipe)

A. Assemble Vent Sections . . . . .	40
B. Secure the Vent Sections . . . . .	41
C. Disassemble Vent Sections . . . . .	41
D. Install Metal Roof Flashing . . . . .	42
E. Assemble and Install Storm Collar . . . . .	42
F. Install Vertical Termination Cap . . . . .	43
G. Heat Shield Requirements for Horizontal Termination . . . . .	43
H. Install Horizontal Termination Cap . . . . .	43

### 11 Gas Information

A. Fuel Conversion . . . . .	44
B. Gas Pressure . . . . .	44
C. Gas Connection . . . . .	44
D. High Altitude Installations . . . . .	44

### 12 Electrical Information

A. Wiring Requirements . . . . .	45
B. IntelliFire Plus™ Ignition System Wiring . . . . .	45
C. Optional Accessories Requirements . . . . .	45
D. Electrical Service and Repair . . . . .	46
E. Junction Box Installation . . . . .	46

### 13 Finishing

A. Finishing Templates . . . . .	47
B. Splatter Guard . . . . .	48
C. Mantel and Wall Projections . . . . .	49
D. Facing Material . . . . .	51
E. Doors . . . . .	52

## 14 Appliance Setup

A. Remove Fixed Glass Assembly . . . . .	53
B. Remove the Shipping Materials . . . . .	53
C. Clean the Appliance . . . . .	53
D. Accessories . . . . .	53
E. Install Teco-Sil and Mystic Embers . . . . .	53
F. Glowing Ember Placement . . . . .	54
G. LED's . . . . .	54
H. Install the Log Assembly . . . . .	55
I. Fixed Glass Assembly . . . . .	61
J. Air Shutter Setting . . . . .	63

## 15 Troubleshooting

A. IntelliFire Plus™ Ignition System . . . . .	64
--	----

## 16 Reference Materials

A. Appliance Dimension Diagram . . . . .	66
B. Vent Components Diagrams . . . . .	68
C. Service Parts . . . . .	72
D. Contact Information . . . . .	80

➔ = Contains updated information.

## B. Limited Lifetime Warranty

### Hearth & Home Technologies Inc. LIMITED LIFETIME WARRANTY

Hearth & Home Technologies Inc., on behalf of its hearth brands ("HHT"), extends the following warranty for HHT gas, wood, pellet, coal and electric hearth appliances that are purchased from an HHT authorized dealer.

#### **WARRANTY COVERAGE:**

HHT warrants to the original owner of the HHT appliance at the site of installation, and to any transferee taking ownership of the appliance at the site of installation within two years following the date of original purchase, that the HHT appliance will be free from defects in materials and workmanship at the time of manufacture. After installation, if covered components manufactured by HHT are found to be defective in materials or workmanship during the applicable warranty period, HHT will, at its option, repair or replace the covered components. HHT, at its own discretion, may fully discharge all of its obligations under such warranties by replacing the product itself or refunding the verified purchase price of the product itself. The maximum amount recoverable under this warranty is limited to the purchase price of the product. This warranty is subject to conditions, exclusions and limitations as described below.

#### **WARRANTY PERIOD:**

Warranty coverage begins on the date of original purchase. In the case of new home construction, warranty coverage begins on the date of first occupancy of the dwelling or six months after the sale of the product by an independent, authorized HHT dealer/ distributor, whichever occurs earlier. The warranty shall commence no later than 24 months following the date of product shipment from HHT, regardless of the installation or occupancy date. The warranty period for parts and labor for covered components is produced in the following table.

The term "Limited Lifetime" in the table below is defined as: 20 years from the beginning date of warranty coverage for gas appliances, and 10 years from the beginning date of warranty coverage for wood, pellet, and coal appliances. These time periods reflect the minimum expected useful lives of the designated components under normal operating conditions.

Warranty Period		HHT Manufactured Appliances and Venting							Components Covered
Parts	Labor	Gas	Wood	Pellet	EPA Wood	Coal	Electric	Venting	
1 Year		X	X	X	X	X	X	X	All parts and material except as covered by Conditions, Exclusions, and Limitations listed
2 years				X	X	X			Igniters, electronic components, and glass
		X	X	X	X	X			Factory-installed blowers
			X						Molded refractory panels
3 years				X					Firepots and burnpots
5 years	1 year			X	X				Castings and baffles
7 years	3 years		X	X	X				Manifold tubes, HHT chimney and termination
10 years	1 year	X							Burners, logs and refractory
Limited Lifetime	3 years	X	X	X	X	X			Firebox and heat exchanger
90 Days		X	X	X	X	X	X	X	All replacement parts beyond warranty period

See conditions, exclusions, and limitations on next page.

## **B. Limited Lifetime Warranty (*continued*)**

### **WARRANTY CONDITIONS:**

- This warranty only covers HHT appliances that are purchased through an HHT authorized dealer or distributor. A list of HHT authorized dealers is available on the HHT branded websites.
- This warranty is only valid while the HHT appliance remains at the site of original installation.
- Contact your installing dealer for warranty service. If the installing dealer is unable to provide necessary parts, contact the nearest HHT authorized dealer or supplier. Additional service fees may apply if you are seeking warranty service from a dealer other than the dealer from whom you originally purchased the product.
- Check with your dealer in advance for any costs to you when arranging a warranty call. Travel and shipping charges for parts are not covered by this warranty.

### **WARRANTY EXCLUSIONS:**

This warranty does not cover the following:

- Changes in surface finishes as a result of normal use. As a heating appliance, some changes in color of interior and exterior surface finishes may occur. This is not a flaw and is not covered under warranty.
- Damage to printed, plated, or enameled surfaces caused by fingerprints, accidents, misuse, scratches, melted items, or other external sources and residues left on the plated surfaces from the use of abrasive cleaners or polishes.
- Repair or replacement of parts that are subject to normal wear and tear during the warranty period. These parts include: paint, wood, pellet and coal gaskets, firebricks, grates, flame guides, light bulbs, batteries and the discoloration of glass.
- Minor expansion, contraction, or movement of certain parts causing noise. These conditions are normal and complaints related to this noise are not covered by this warranty.
- Damages resulting from: (1) failure to install, operate, or maintain the appliance in accordance with the installation instructions, operating instructions, and listing agent identification label furnished with the appliance; (2) failure to install the appliance in accordance with local building codes; (3) shipping or improper handling; (4) improper operation, abuse, misuse, continued operation with damaged, corroded or failed components, accident, or improperly/incorrectly performed repairs; (5) environmental conditions, inadequate ventilation, negative pressure, or drafting caused by tightly sealed constructions, insufficient make-up air supply, or handling devices such as exhaust fans or forced air furnaces or other such causes; (6) use of fuels other than those specified in the operating instructions; (7) installation or use of components not supplied with the appliance or any other components not expressly authorized and approved by HHT; (8) modification of the appliance not expressly authorized and approved by HHT in writing; and/or (9) interruptions or fluctuations of electrical power supply to the appliance.
- Non-HHT venting components, hearth components or other accessories used in conjunction with the appliance.
- Any part of a pre-existing fireplace system in which an insert or a decorative gas appliance is installed.
- HHT's obligation under this warranty does not extend to the appliance's capability to heat the desired space. Information is provided to assist the consumer and the dealer in selecting the proper appliance for the application. Consideration must be given to appliance location and configuration, environmental conditions, insulation and air tightness of the structure.

### **This warranty is void if:**

- The appliance has been over-fired or operated in atmospheres contaminated by chlorine, fluorine, or other damaging chemicals. Over-firing can be identified by, but not limited to, warped plates or tubes, rust colored cast iron, bubbling, cracking and discoloration of steel or enamel finishes.
- The appliance is subjected to prolonged periods of dampness or condensation.
- There is any damage to the appliance or other components due to water or weather damage which is the result of, but not limited to, improper chimney or venting installation.

### **LIMITATIONS OF LIABILITY:**

- The owner's exclusive remedy and HHT's sole obligation under this warranty, under any other warranty, express or implied, or in contract, tort or otherwise, shall be limited to replacement, repair, or refund, as specified above. In no event will HHT be liable for any incidental or consequential damages caused by defects in the appliance. Some states do not allow exclusions or limitation of incidental or consequential damages, so these limitations may not apply to you. This warranty gives you specific rights; you may also have other rights, which vary from state to state. EXCEPT TO THE EXTENT PROVIDED BY LAW, HHT MAKES NO EXPRESS WARRANTIES OTHER THAN THE WARRANTY SPECIFIED HEREIN. THE DURATION OF ANY IMPLIED WARRANTY IS LIMITED TO DURATION OF THE EXPRESSED WARRANTY SPECIFIED ABOVE.

# 1 Listing and Code Approvals

## A. Appliance Certification

**MODELS:** TRUE-36C, TRUE-36H, TRUE-36S,  
TRUE-42C, TRUE-42H, TRUE-42S  
TRUE-50C, TRUE-50H, TRUE-50S  
**LABORATORY:** Underwriters Laboratories, Inc. (UL)  
**TYPE:** Direct Vent Gas Appliance Heater  
**STANDARD:** ANSI Z21.88-2009 • CSA 2.33-2009

This product is listed to ANSI standards for “Vented Gas Appliance Heaters” and applicable sections of “Gas Burning Heating Appliances for Manufactured Homes and Recreational Vehicles”, and “Gas Fired Appliances for Use at High Altitudes”.

**NOTICE:** This installation must conform with local codes. In the absence of local codes you must comply with the National Fuel Gas Code, ANSI Z223.1-latest edition in the U.S.A. and the CAN/CGA B149 Installation Codes in Canada.

**NOT INTENDED FOR USE AS A PRIMARY HEAT SOURCE.**  
This appliance is tested and approved as either supplemental room heat or as a decorative appliance. It should not be factored as primary heat in residential heating calculations.

## B. Glass Specifications

This appliance is equipped with 5 mm ceramic glass with an anti-reflective coating. Replace glass only with glass with identical specifications. Please contact your dealer for replacement glass.

## C. BTU Specifications

Models (U.S. or Canada)		Maximum Input BTU/h	Minimum Input BTU/h	Orifice Size (DMS)
TRUE-36 (NG)	US (0-2000 FT)	45,500	28,000	#30
	CANADA (2000-4500 FT)	41,000	25,000	#31
TRUE-36 (LP)	US (0-2000 FT)	43,500	27,500	#47
	CANADA (2000-4500 FT)	39,000	25,000	#48
TRUE-42 (NG)	US (0-2000 FT)	55,500	30,500	#26
	CANADA (2000-4500 FT)	50,000	27,500	#27
TRUE-42 (LP)	US (0-2000 FT)	51,500	29,000	#45
	CANADA (2000-4500 FT)	46,500	26,000	#46
TRUE-50 (NG)	US (0-2000 FT)	65,000	36,000	#24
	CANADA (2000-4500 FT)	58,500	32,500	#25
TRUE-50 (LP)	US (0-2000 FT)	63,500	32,500	#43
	CANADA (2000-4500 FT)	57,000	29,500	#44

## D. High Altitude Installations

**NOTICE:** If the heating value of the gas has been reduced, these rules do not apply. Check with your local gas utility or authorities having jurisdiction.

When installing above 2000 feet elevation:

- In the USA: Reduce input rate 4% for each 1000 feet above 2000 feet.
- In CANADA: Reduce input rate 10% for elevations between 2000 feet and 4500 feet. Above 4500 feet, consult local gas utility.

Check with your local gas utility to determine proper orifice size.

## E. Non-Combustible Materials Specification

Material which will not ignite and burn. Such materials are those consisting entirely of steel, iron, brick, tile, concrete, slate, glass or plasters, or any combination thereof.

Materials that are reported as passing **ASTM E 136, Standard Test Method for Behavior of Materials in a Vertical Tube Furnace at 750 °C** and **UL763** shall be considered non-combustible materials.

## F. Combustible Materials Specification

Materials made of or surfaced with wood, compressed paper, plant fibers, plastics, or other material that can ignite and burn, whether flame proofed or not, or plastered or unplastered shall be considered combustible materials.

## G. Electrical Codes

**NOTICE:** This appliance must be electrically wired and grounded in accordance with local codes or, in the absence of local codes, with **National Electric Code ANSI/NFPA 70-latest edition** or the **Canadian Electric Code CSA C22.1**.

- A 110-120 VAC circuit for this product must be protected with ground-fault circuit-interrupter protection, in compliance with the applicable electrical codes, when it is installed in locations such as in bathrooms or near sinks.

**Note:** The following requirements reference various Massachusetts and national codes not contained in this document.

## H. Requirements for the Commonwealth of Massachusetts

For all side wall horizontally vented gas fueled equipment installed in every dwelling, building or structure used in whole or in part for residential purposes, including those owned or operated by the Commonwealth and where the side wall exhaust vent termination is less than seven (7) feet above finished grade in the area of the venting, including but not limited to decks and porches, the following requirements shall be satisfied:

### Installation of Carbon Monoxide Detectors

At the time of installation of the side wall horizontal vented gas fueled equipment, the installing plumber or gas fitter shall observe that a hard wired carbon monoxide detector with an alarm and battery back-up is installed on the floor level where the gas equipment is to be installed. In addition, the installing plumber or gas fitter shall observe that a battery operated or hard wired carbon monoxide detector with an alarm is installed on each additional level of the dwelling, building or structure served by the side wall horizontal vented gas fueled equipment. It shall be the responsibility of the property owner to secure the services of qualified licensed professionals for the installation of hard wired carbon monoxide detectors.

In the event that the side wall horizontally vented gas fueled equipment is installed in a crawl space or an attic, the hard wired carbon monoxide detector with alarm and battery back-up may be installed on the next adjacent floor level.

In the event that the requirements of this subdivision can not be met at the time of completion of installation, the owner shall have a period of thirty (30) days to comply with the above requirements; provided, however, that during said thirty (30) day period, a battery operated carbon monoxide detector with an alarm shall be installed.

### Approved Carbon Monoxide Detectors

Each carbon monoxide detector as required in accordance with the above provisions shall comply with NFPA 720 and be ANSI/UL 2034 listed and IAS certified.

### Signage

A metal or plastic identification plate shall be permanently mounted to the exterior of the building at a minimum height of eight (8) feet above grade directly in line with the exhaust vent terminal for the horizontally vented gas fueled heating appliance or equipment. The sign shall read, in print size no less than one-half (1/2) in. in size, "**GAS VENT DIRECTLY BELOW. KEEP CLEAR OF ALL OBSTRUCTIONS**".

## Inspection

The state or local gas inspector of the side wall horizontally vented gas fueled equipment shall not approve the installation unless, upon inspection, the inspector observes carbon monoxide detectors and signage installed in accordance with the provisions of 248 CMR 5.08(2)(a)1 through 4.

## Exemptions

The following equipment is exempt from 248 CMR 5.08(2)(a)1 through 4:

- The equipment listed in Chapter 10 entitled "Equipment Not Required To Be Vented" in the most current edition of NFPA 54 as adopted by the Board; and
- Product Approved side wall horizontally vented gas fueled equipment installed in a room or structure separate from the dwelling, building or structure used in whole or in part for residential purposes.

## MANUFACTURER REQUIREMENTS

### Gas Equipment Venting System Provided

When the manufacturer of Product Approved side wall horizontally vented gas equipment provides a venting system design or venting system components with the equipment, the instructions provided by the manufacturer for installation of the equipment and the venting system shall include:

- Detailed instructions for the installation of the venting system design or the venting system components; and
- A complete parts list for the venting system design or venting system.

### Gas Equipment Venting System NOT Provided

When the manufacturer of a Product Approved side wall horizontally vented gas fueled equipment does not provide the parts for venting the flue gases, but identifies "special venting systems", the following requirements shall be satisfied by the manufacturer:

- The referenced "special venting system" instructions shall be included with the appliance or equipment installation instructions; and
- The "special venting systems" shall be Product Approved by the Board, and the instructions for that system shall include a parts list and detailed installation instructions.

A copy of all installation instructions for all Product Approved side wall horizontally vented gas fueled equipment, all venting instructions, all parts lists for venting instructions, and/or all venting design instructions shall remain with the appliance or equipment at the completion of the installation.

**See Gas Connection section for additional Commonwealth of Massachusetts requirements.**



## A. Gas Fireplace Safety

### ⚠ WARNING



#### HOT SURFACES!

Glass and other surfaces are hot during operation AND cool down.

#### Hot glass will cause burns.

- **DO NOT** touch glass until it is cooled
- **NEVER** allow children to touch glass
- Keep children away

- **CAREFULLY SUPERVISE** children in same room as fireplace.
- Alert children and adults to hazards of high temperatures.

#### High temperatures may ignite clothing or other flammable materials.

- Keep clothing, furniture, draperies and other flammable materials away.

***This appliance has been supplied with an integral barrier to prevent direct contact with the fixed glass panel. DO NOT operate the appliance with the barrier removed.***

Contact your dealer or Hearth & Home Technologies if the barrier is not present or help is needed to properly install one.

If you expect that small children or vulnerable adults may come into contact with this fireplace, the following precautions are recommended:

- Install a physical barrier such as:
  - A decorative firescreen.
  - Adjustable safety gate.
- Install a switch lock or a wall/remote control with child protection lockout feature.

- Keep remote controls out of reach of children.
- Never leave children alone near a hot fireplace, whether operating or cooling down.
- Teach children to **NEVER** touch the fireplace.
- Consider not using the fireplace when children will be present.

Contact your dealer for more information, or visit: [www.hpba.org/safety-information](http://www.hpba.org/safety-information).

To prevent unintended operation when not using your fireplace for an extended period of time (summer months, vacations, trips, etc):

- Remove batteries from remote controls.
- Turn off wall controls.
- Set the selector switch on the control module to the OFF position and remove batteries.

## B. Your Fireplace

***WARNING! DO NOT operate fireplace before reading and understanding operating instructions. Failure to operate fireplace according to operating instructions could cause fire or injury.***

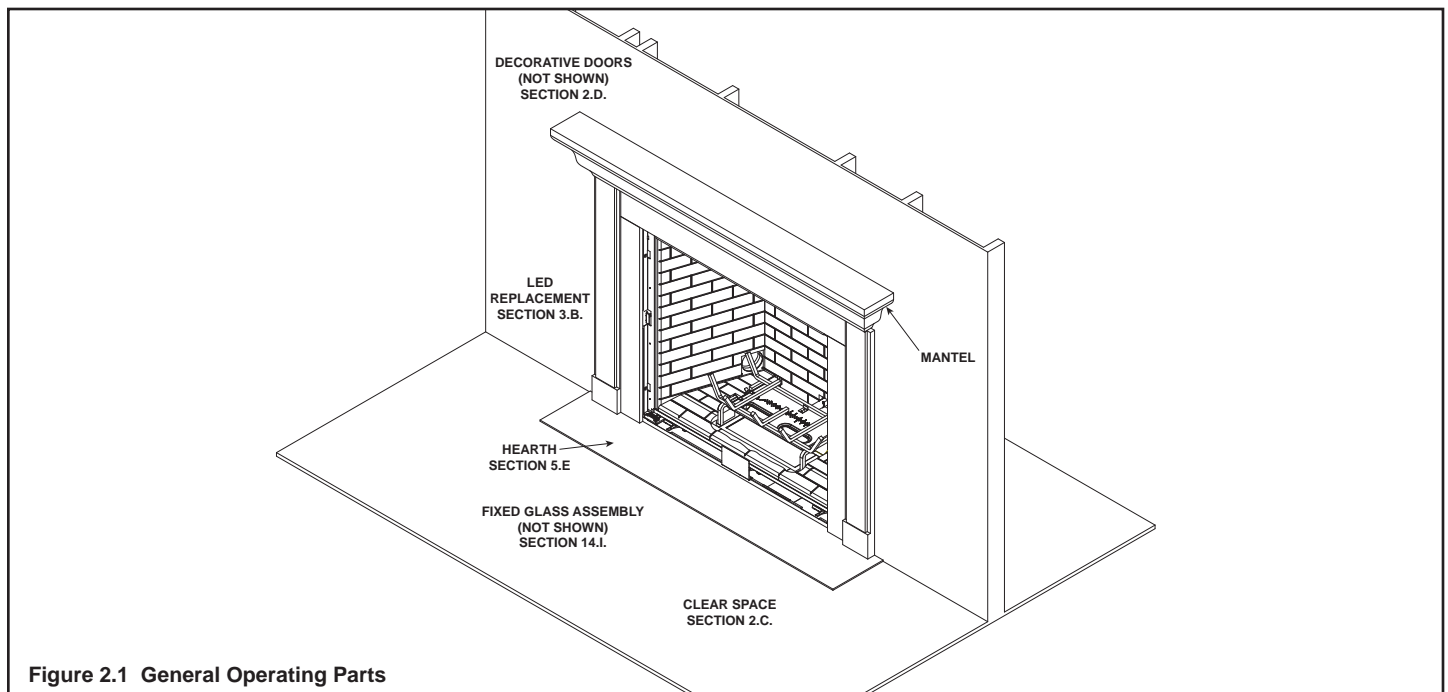

Figure 2.1 General Operating Parts

### C. Clear Space

**WARNING! DO NOT** place combustible objects in front of the fireplace or block louvers. High temperatures may start a fire. See Figure 2.2.

Avoid placing candles and other heat-sensitive objects on mantel or hearth. Heat may damage these objects.

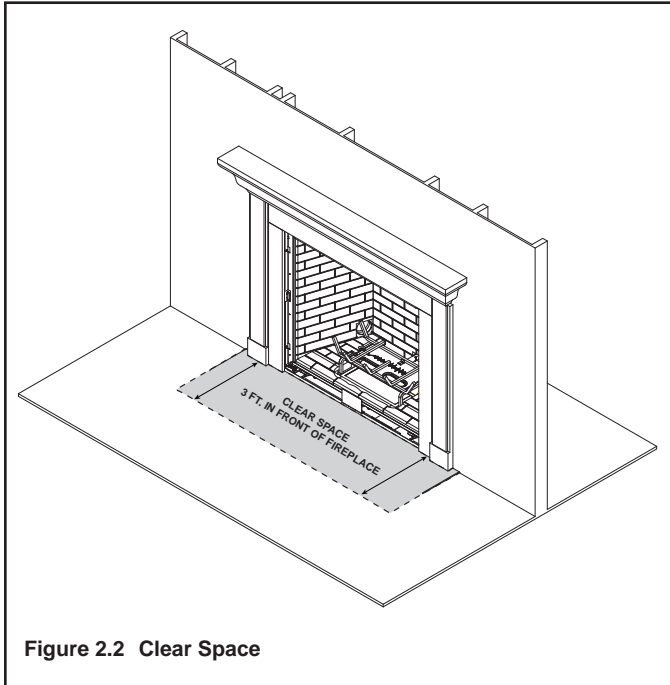

Figure 2.2 Clear Space

### D. Decorative Doors and Fronts

**WARNING! Risk of Fire!** Install **ONLY** doors or fronts approved by Hearth & Home Technologies. Unapproved doors or fronts may cause fireplace to overheat.

**This fireplace has been supplied with an integral barrier to prevent direct contact with the fixed glass panel. DO NOT operate the fireplace with the barrier removed.**

Contact your dealer or Hearth & Home Technologies if the barrier is not present or help is needed to properly install one.

For more information refer to the instructions supplied with your decorative door or front.

### E. Fixed Glass Assembly

See Section 14.1.

### F. Remote Controls, Wall Controls and Wall Switches

Follow the instructions supplied with the control installed to operate your fireplace:

For safety:

- Install a switch lock or a wall/remote control with child protection lockout feature.
- Keep remote controls out of reach of children.

See your dealer if you have questions.

### G. IPI Battery Tray/Battery Installation

The IntelliFire Plus™ system has a battery backup option. Battery longevity and performance will be affected by the service temperatures of this appliance.

**NOTICE:** Batteries should only be used as a power source in the event of an emergency such as an outage.

### H. Rating Plate/Glass Clip Tool Location

The rating plate for this model is located underneath the firebox affixed to a tray that must be accessed using a 1/4 inch nut driver. See Figure 2.3. To access the rating plate, remove the screw that secures the tray to the appliance bottom and pull the tray out.

The glass clip removal/installation tool is also located in this area. To access the glass clip tool, remove the screw that secures it to the appliance bottom.

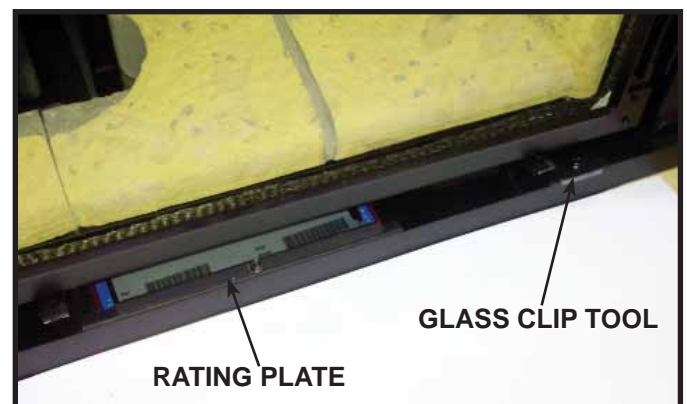

Figure 2.3 Rating Plate/Glass Clip Tool Location

## I. Control Module Operation

1. The control module has an ON/OFF/REMOTE selector switch that must be set. See Figure 2.4.

**OFF Position:** Appliance will ignore all power inputs and will not respond to any commands from a wall switch or remote. The unit should be in the OFF position during installation, service, battery installation, fuel conversion, and in the event that the control goes into LOCK-OUT mode as a result of an error code.

**ON Position:** Appliance will ignite and run continuously in the HI flame setting, with no adjustment in flame output. This mode of operation is primarily used for initial installation or power outage operation with battery backup.

**REMOTE Position:** Appliance will initiate commands from an optional wired wall switch and/or the wireless remote (RC300).

2. If using a wired wall switch with the module in REMOTE mode, the flame output can be adjusted with the HI/LO selector switch on the module. See Figure 2.4. Note that the flame HI/LO selector switch will become inactive once an optional remote control (RC300) is programmed to the control module. Note that the control module will always ignite the fireplace on HI and remain so for the initial 10 seconds of operation. If the HI/LO is switched to the LO position, the flame output will automatically drop to the lowest setting after the flame has been established for 10 sec. After this 10 second period, the flame can be adjusted from HI to LO with the switch.
3. The control module has safety feature that automatically shuts down the fireplace after 9 hours of continuous operation without receiving a command from the RC300 remote.
4. If you intend to use both an optional wired wall switch and the RC300 remote control to operate your fireplace, the wall switch will override any commands given by the remote.

### 5. Module Reset

This module may lock-out under certain conditions. When this occurs, the appliance will not ignite or respond to commands. The module will go into lock-out mode by emitting three audible beeps, then continuously displaying a RED/GREEN error code at its status indicator LED.

- Locate the module selector switch. (See Figure 2.4).
- Set the module selector switch to the OFF position.
- Wait five (5) minutes to allow possible accumulated gas to clear.
- Set the module selector switch to ON or REMOTE position.
- Start the appliance.

**WARNING! Risk of Explosion! DO NOT** reset the module more than one time within a five minute time period. Gas may accumulate in firebox. Call a qualified service technician.

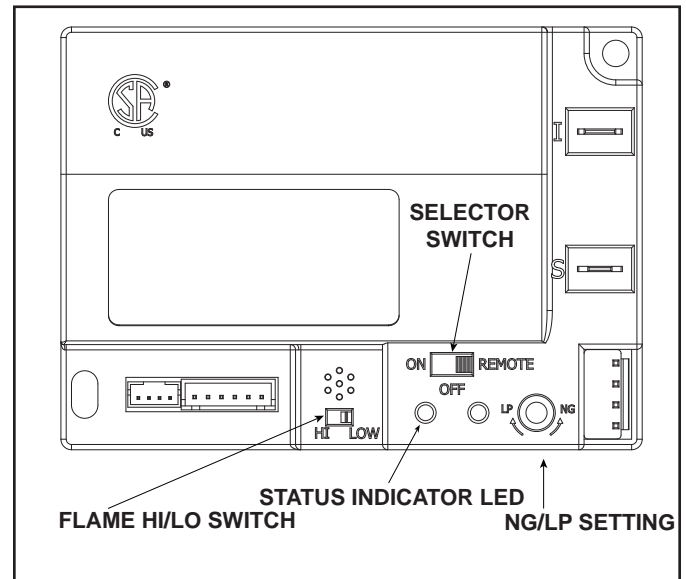

Figure 2.4 Control Module

### Nine Hour Safety Shutdown Feature

This appliance has a safety feature that automatically shuts down the fireplace after 9 hours of continuous operation without receiving a command from the RC300 remote.

## J. Before Lighting Fireplace

Before operating this fireplace for the first time, **have a qualified service technician:**

- Verify all shipping materials have been removed from inside and/or underneath the firebox.
- Review proper placement of logs, ember material and/or other decorative materials.
- Check the wiring.
- Check the air shutter adjustment.
- Ensure that there are no gas leaks.
- Ensure that the glass is sealed and in the proper position and that the integral barrier is in place.

**WARNING! Risk of Fire or Asphyxiation! DO NOT** operate fireplace with fixed glass assembly removed.

## K. Lighting Instructions (IPI)

### FOR YOUR SAFETY READ BEFORE LIGHTING

**WARNING:** If you do not follow these instructions exactly, a fire or explosion may result causing property damage, personal injury or loss of life.

- A.** This appliance is equipped with an intermittent pilot ignition (IPI) device which automatically lights the burner. **DO NOT** try to light the burner by hand.
- Immediately call your gas supplier from a neighbor's phone. Follow the gas supplier's instructions.
  - If you cannot reach your gas supplier, call the fire department.

- B. BEFORE LIGHTING,** smell all around the appliance area for gas. Be sure to smell next to the floor because some gas is heavier than air and will settle on the floor.
- C. DO NOT** use this appliance if any part has been under water. Immediately call a qualified service technician to inspect the appliance and to replace any part of the control system and any gas control which has been under water.

#### WHAT TO DO IF YOU SMELL GAS

- **DO NOT** try to light any appliance.
- **DO NOT** touch any electric switch; do not use any phone in your building.

### WARNING:

**DO NOT CONNECT LINE VOLTAGE (110/120 VAC OR 220/240 VAC) TO THE CONTROL VALVE.**

Improper installation, adjustment, alteration, service or maintenance can cause injury or property damage. Refer to the owner's information manual provided with this appliance.

This appliance needs fresh air for safe operation and must be installed so there are provisions for adequate combustion and ventilation air.

If not installed, operated, and maintained in accordance with the manufacturer's instructions, this product could expose you to substances in fuel or fuel combustion which are known to the State of California to cause cancer, birth defects, or other reproductive harm.

Keep burner and control compartment clean. See installation and operating instructions accompanying appliance.

For additional information on operating your  
Hearth & Home Technologies fireplace, please refer to [www.fireplaces.com](http://www.fireplaces.com).

### CAUTION:

Hot while in operation. **DO NOT** touch. Keep children, clothing, furniture, gasoline and other liquids having flammable vapors away.

**DO NOT** operate the appliance with fixed glass assembly removed, cracked or broken. Replacement of the fixed glass assembly should be done by a licensed or qualified service person.

### NOT FOR USE WITH SOLID FUEL

For use with natural gas and propane. A conversion kit, as supplied by the manufacturer, shall be used to convert this appliance to the alternate fuel.

**Also Certified for Installation in a Bedroom or a Bedsitting Room.**

For assistance or additional information, consult a qualified installer, service agency or the gas supplier.

### LIGHTING INSTRUCTIONS (IPI)

1. This appliance is equipped with an ignition device which automatically lights the burner. **DO NOT** try to light the burner by hand.

**GAS  
VALVE**

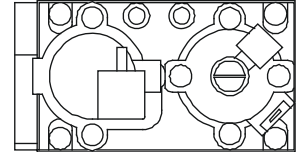

2. Wait five (5) minutes to clear out any gas. Then smell for gas, including near the floor. If you smell gas, **STOP!** Follow "B" in the Safety Information located on the left side of this label. If you do not smell gas, go to next step.
3. To light the burner:  
Equipped with wall switch: Turn ON/OFF switch to ON.  
Equipped with remote or wall control: Press ON or FLAME button.  
Equipped with thermostat: Set temperature to desired setting.
4. If the appliance does not light after three tries, call your service technician or gas supplier.

### TO TURN OFF GAS TO APPLIANCE

1. Equipped with wall switch: Turn ON/OFF switch to OFF.  
Equipped with remote or wall control: Press OFF button.  
Equipped with thermostat: Set temperature to lowest setting.
2. Service technician should turn off electric power to the control when performing service.

593-913G

Final inspection by \_\_\_\_\_

## L. After Fireplace is Lit

### Initial Break-in Procedure

- The fireplace should be run three to four hours continuously on high.
- Turn the fireplace off and allow it to completely cool.
- Remove fixed glass assembly. See Section 14.1.
- Clean fixed glass assembly. See Section 3.
- Replace the fixed glass assembly and run continuously on high an additional 12 hours.

This cures the materials used to manufacture the fireplace.

### **NOTICE! Open windows for air circulation during fireplace break-in.**

- Some people may be sensitive to smoke and odors.
- Smoke detectors may activate.

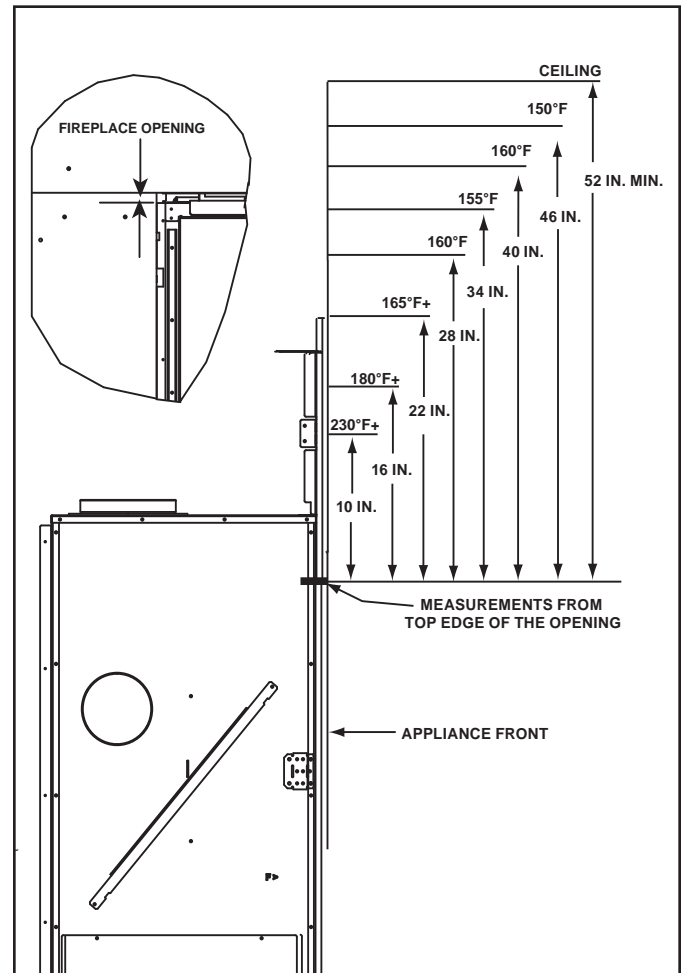

Figure 2.4 Wall Surface Temperatures

## M. Frequently Asked Questions

ISSUE	SOLUTIONS
Condensation on the glass	This is a result of gas combustion and temperature variations. As the fireplace warms, this condensation will disappear.
Blue flames	This is a result of normal operation and the flames will begin to yellow as the fireplace is allowed to burn for 20 to 40 minutes.
Odor from fireplace	When first operated, this fireplace may release an odor for the first several hours. This is caused by the curing of the paint and the burning off of any oils remaining from manufacturing. Odor may also be released from finishing materials and adhesives used around the fireplace.
Film on the glass	This is a normal result of the curing process of the paint and logs. Glass should be cleaned within 3 to 4 hours of initial burning to remove deposits left by oils from the manufacturing process. A non-abrasive cleaner such as gas fireplace glass cleaner may be necessary. See your dealer.
Metallic noise	Noise is caused by metal expanding and contracting as it heats up and cools down, similar to the sound produced by a furnace or heating duct. This noise does not affect the operation or longevity of the fireplace.
Is it normal to see the pilot flame burn continually?	In an intermittent pilot ignition system (IPI), the pilot flame should turn off when appliance is turned off. Some optional control systems available with IPI models may allow pilot flame to remain lit.

# 3 Maintenance and Service

Any safety screen or guard removed for servicing must be replaced prior to operating the fireplace.

When properly maintained, your fireplace will give you many years of trouble-free service. We recommend annual service by a qualified service technician.

## A. Maintenance Tasks-Homeowner

Installation and repair should be done by a qualified service technician only. The fireplace should be inspected before use and at least annually by a professional service person.

The following tasks may be performed annually by the homeowner. If you are uncomfortable performing any of the listed tasks, please call your dealer for a service appointment.

More frequent cleaning may be required due to lint from carpeting or other factors. Control compartment, burner and circulating air passageway of the fireplace must be kept clean.

**CAUTION! Risk of Burns!** *The fireplace should be turned off and cooled before servicing.*

## Glass Cleaning

### (Exterior of Installed Glass Only)

**Frequency:** Seasonally

**By:** Homeowner

**Tools Needed:** Protective gloves, ceramic glass cleaner, drop cloth and a stable work surface.

**WARNING! Risk of Injury!** *Glass installation and removal must be performed only by a qualified service technician.*

- Homeowner may only clean outsides of glass.
- Call your dealer for a service appointment to have inside of glass cleaned.

**CAUTION! Glass is breakable.**

- Avoid striking, scratching or slamming glass
- Avoid abrasive cleaners
- **DO NOT** clean glass while it is hot
- Clean glass with a non-abrasive commercially available ceramic glass cleaner.

**NOTICE! Use only glass cleaner compatible with ceramic glass.** *Other types of glass cleaner may damage the glass surface when exposed to high temperatures.*

- Light deposits: Use a soft cloth with soap and water
- Heavy deposits: Use commercial fireplace glass cleaner (consult with your dealer)

## Doors, Surrounds, Fronts

**Frequency:** Annually

**By:** Homeowner

**Tools needed:** Protective gloves, stable work surface

- Assess condition of screen and replace as necessary.
- Inspect for scratches, dents or other damage and repair as necessary.
- Check that louvers are not blocked.
- Vacuum and dust surfaces.

## Remote Control

**Frequency:** Seasonally

**By:** Homeowner

**Tools needed:** Replacement batteries and remote control instructions.

- Locate remote control transmitter and receiver.
- Verify operation of remote. Refer to remote control operation instructions for proper calibration and setup procedure.
- Replace batteries as needed in remote transmitters.
- Place remote control out of reach of children.

If not using your fireplace for an extended period of time (summer months, vacations/trips, etc), to prevent unintended operation:

- Remove batteries from remote controls.
- Turn the ON/OFF/REMOTE switch on the control module to OFF.

## Venting

**Frequency:** Seasonally

**By:** Homeowner

**Tools needed:** Protective gloves and safety glasses.

- Inspect venting and termination cap for blockage or obstruction such plants, bird nests, leaves, snow, debris, etc.
- Verify termination cap clearance to subsequent construction (building additions, decks, fences, or sheds). See Section 6.
- Inspect for corrosion or separation.
- Verify weather stripping, sealing and flashing remains intact.

## B. Maintenance Tasks-Qualified Service Technician

The following tasks must be performed by a qualified service technician.

### Glass Cleaning

#### (Exterior and Interior of Installed Glass)

**Frequency:** Seasonally

**By:** Qualified Service Technician

**Tools Needed:** Protective gloves, ceramic glass cleaner, drop cloth and a stable work surface.

**WARNING! Risk of Injury!** Glass installation and removal must be performed only by a qualified service technician.

**CAUTION! Handle fixed glass assembly with care.** Glass is breakable.

- Avoid striking, scratching or slamming glass
- Avoid abrasive cleaners
- **DO NOT** clean glass while it is hot

**NOTICE! Use only glass cleaner compatible with ceramic glass.** Other types of glass cleaner may damage the glass surface when exposed to high temperatures.

- Prepare a work area large enough to accommodate fixed glass assembly and door frame by placing a drop cloth on a flat, stable surface.

**Note:** Fixed glass assembly and gasketing may have residue that can stain carpeting or floor surfaces.

- Remove door or decorative front from fireplace and set aside on work surface.
- See Section 14.I for instructions to remove fixed glass assembly.
- Clean glass with a non-abrasive commercially available ceramic glass cleaner.
  - Light deposits: Use a soft cloth with soap and water.
  - Heavy deposits: Use commercial fireplace glass cleaner (consult with your dealer).
- See Section 14.I for instructions to replace the fixed glass assembly.
- Reinstall door or decorative front.

### Gasket Seal and Glass Assembly Inspection

**Frequency:** Annually

**By:** Qualified Service Technician

**Tools needed:** Protective gloves, drop cloth and a stable work surface.

- Inspect gasket seal and its condition.
- Inspect fixed glass assembly for scratches and nicks that can lead to breakage when exposed to heat.
- Confirm there is no damage to glass or glass frame. Replace as necessary.

- Verify that fixed glass assembly is properly retained and attachment components are intact and not damaged. Replace as necessary.

### Logs

**Frequency:** Annually

**By:** Qualified Service Technician

**Tools needed:** Protective gloves.

- Inspect for damaged or missing logs. Replace as necessary. Refer to Section 14 for log placement instructions.
- Verify correct log placement and no flame impingement causing sooting. Correct as necessary.

### Firebox

**Frequency:** Annually

**By:** Qualified Service Technician

**Tools needed:** Protective gloves, sandpaper, steel wool, cloths, mineral spirits, primer and touch-up paint.

- Inspect for paint condition, warped surfaces, corrosion or perforation. Sand and repaint as necessary.
- Replace fireplace if firebox has been perforated.

### Control Compartment and Firebox Top

**Frequency:** Annually

**By:** Qualified Service Technician

**Tools needed:** Protective gloves, vacuum cleaner, dust cloths

- Vacuum and wipe out dust, cobwebs, debris or pet hair. Use caution when cleaning these areas. Screw tips that have penetrated the sheet metal are sharp and should be avoided.
- Remove all foreign objects.
- Verify unobstructed air circulation.

### L.E.D Replacement

**Frequency:** As needed

**By:** Qualified Service Technician

**Tools needed:** Protective gloves, replacement LED assemblies, 1/4 inch nut driver.

The LEDs installed in this appliance do not require any annual service. However, the LED assemblies can be replaced. To replace:

- Remove Logs, Grate/Burner, Base refractory.
- Remove the ember glass assembly. The LED box can be lifted out of the fireplace at this point.
- See replacement parts list for LED part numbers.

## Burner Ignition and Operation

**Frequency:** Annually

**By:** Qualified Service Technician

**Tools needed:** Protective gloves, vacuum cleaner, whisk broom, flashlight, voltmeter, indexed drill bit set, and a manometer.

- Verify burner is properly secured and aligned with pilot or igniter.
- Clean off burner top, inspect for plugged ports, corrosion or deterioration. Replace burner if necessary.
- Verify batteries have been removed from battery back-up IPI systems to prevent premature battery failure or leaking.
- Check for smooth lighting and ignition carryover to all ports. Verify that there is no ignition delay.
- Inspect for lifting or other flame problems.
- Verify air shutter setting is correct. See Section 14 for required air shutter setting. Verify air shutter is clear of dust and debris.
- Inspect orifice for soot, dirt and corrosion. Verify orifice size is correct. See Service Parts List for proper orifice sizing.
- Verify manifold and inlet pressures. Adjust regulator as required.
- Inspect pilot flame pattern and strength. See Figure 3.1 for proper pilot flame pattern. Clean or replace orifice spud as necessary.
- Inspect IPI flame sensing rod for soot, corrosion and deterioration. Polish with fine steel wool or replace as required.
- Verify that there is not a short in flame sense circuit by checking continuity between pilot hood and flame sensing rod. Replace pilot as necessary.



Figure 3.1 IPI Pilot Flame Patterns



# 4 Getting Started

# Installer Guide

## A. Typical Appliance System

**NOTICE:** Illustrations and photos reflect typical installations and are for design purposes only. Illustrations/diagrams are not drawn to scale. Actual product may vary from pictures in manual.

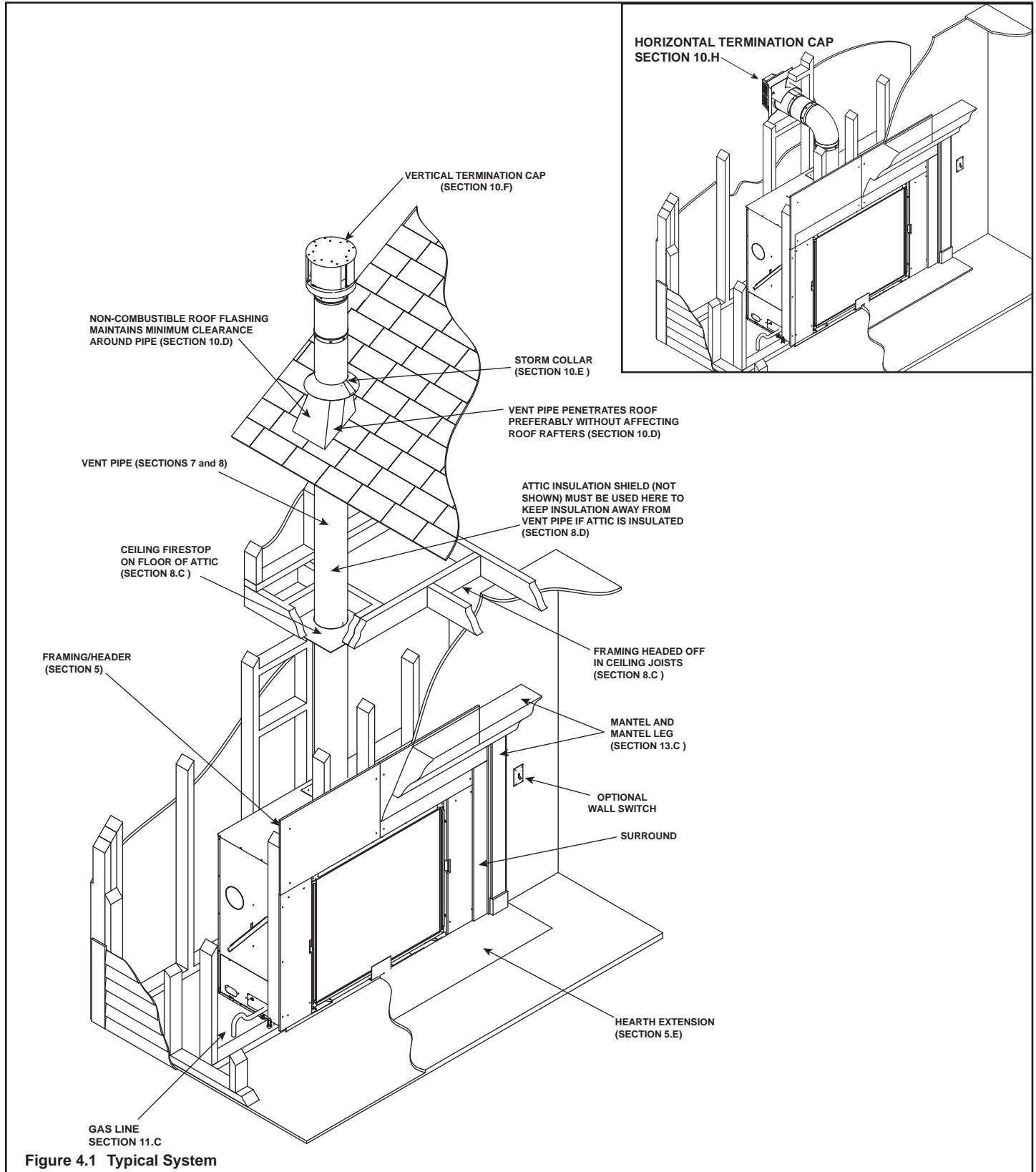

Figure 4.1 Typical System

## B. Design and Installation Considerations

Heat & Glo direct vent gas appliances are designed to operate with all combustion air siphoned from outside of the building and all exhaust gases expelled to the outside. No additional outside air source is required.

Installation **MUST** comply with local, regional, state and national codes and regulations. Consult insurance carrier, local building inspector, fire officials or authorities having jurisdiction over restrictions, installation inspection and permits.

Before installing, determine the following:

- Where the appliance is to be installed.
- The vent system configuration to be used.
- Gas supply piping requirements.
- Electrical wiring requirements.
- Framing and finishing details.
- Whether optional accessories—devices such as a wall switch or remote control—are desired.

Improper installation, adjustment, alteration, service or maintenance can cause injury or property damage. For assistance or additional information, consult a qualified service technician, service agency or your dealer.

## C. Tools and Supplies Needed

Before beginning the installation be sure that the following tools and building supplies are available.

Tape measure	Framing material
Pliers	Hammer
Phillips screwdriver	Manometer
Gloves	Framing square
Voltmeter	Electric drill and bits (1/4 in.)
Plumb line	Safety glasses
Level	Reciprocating saw

Flat blade screwdriver  
Non-corrosive leak check solution  
1/2 - 3/4 in. length, #6 or #8 Self-drilling screws  
Caulking material (300°F minimum continuous exposure rating)

## D. Inspect Appliance and Components

- Carefully remove the appliance and components from the packaging.
- The vent system components and decorative doors and fronts may be shipped in separate packages.
- If packaged separately, the log set and appliance grate must be installed.
- Report to your dealer any parts damaged in shipment, particularly the condition of the glass.
- **Read all of the instructions before starting the installation. Follow these instructions carefully during the installation to ensure maximum safety and benefit.**

**WARNING! Risk of Fire or Explosion!** Damaged parts could impair safe operation. **DO NOT** install damaged, incomplete or substitute components. Keep appliance dry.

Hearth & Home Technologies disclaims any responsibility for, and the warranty will be voided by, the following actions:

- Installation and use of any damaged appliance or vent system component.
- Modification of the appliance or vent system.
- Installation other than as instructed by Hearth & Home Technologies.
- Improper positioning of the gas logs or the glass door.
- Installation and/or use of any component part not approved by Hearth & Home Technologies.

**Any such action may cause a fire hazard.**

**WARNING! Risk of Fire, Explosion or Electric Shock!** **DO NOT** use this appliance if any part has been under water. Call a qualified service technician to inspect the appliance and to replace any part of the control system and/or gas control which has been under water.

# 5 Framing and Clearances

## A. Selecting Appliance Location

When selecting a location for the appliance it is important to consider the required clearances to walls (see Figure 5.1).

**WARNING! Risk of Fire or Burns!** Provide adequate clearance around air openings and for service access. Due to high temperatures, the appliance should be located out of traffic and away from furniture and draperies.

**NOTICE:** Illustrations reflect typical installations and are FOR DESIGN PURPOSES ONLY. Illustrations/diagrams are not drawn to scale. Actual installation may vary due to individual design preference.

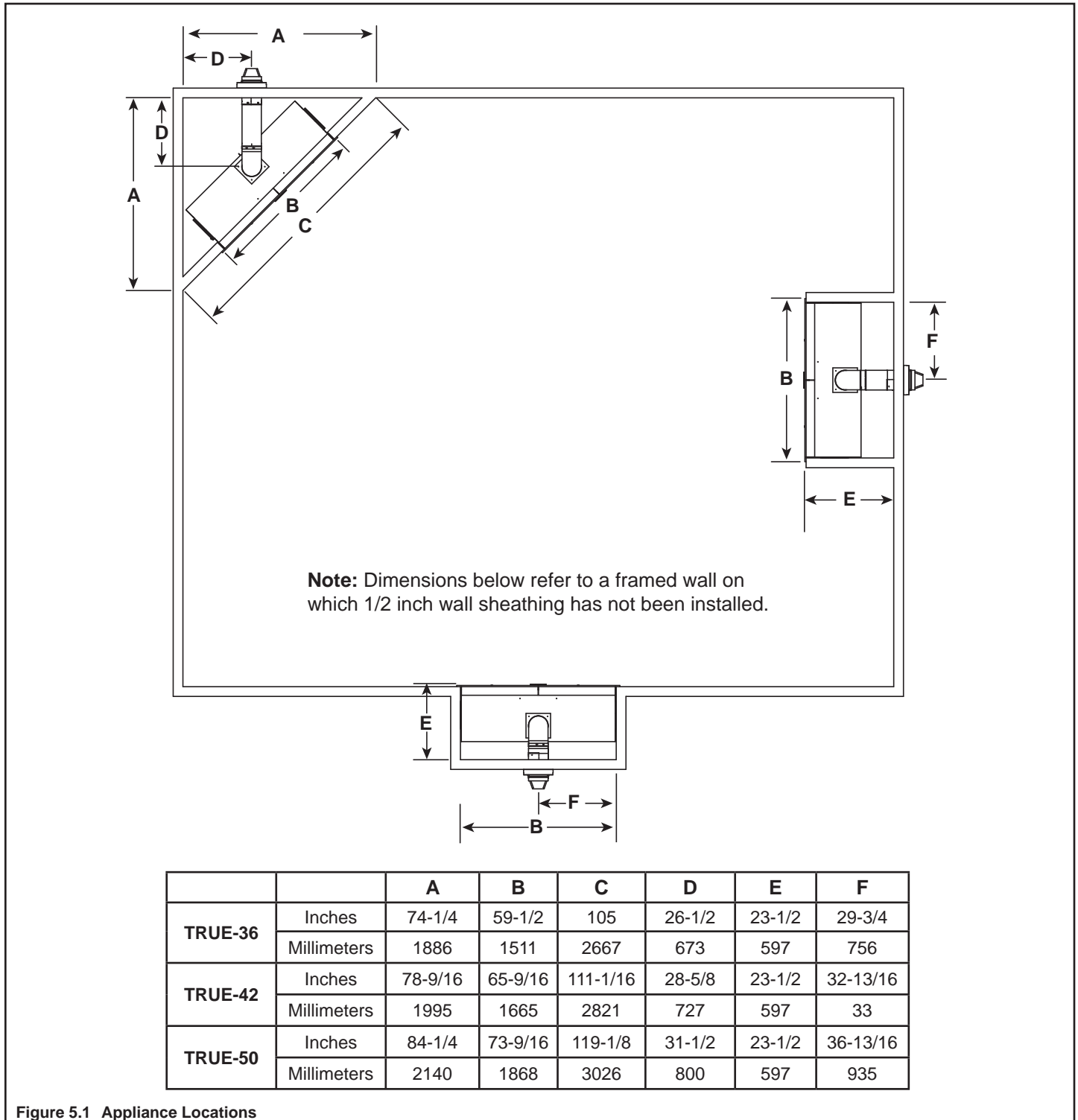

Figure 5.1 Appliance Locations

## B. Constructing the Appliance Chase

A chase is a vertical box-like structure built to enclose the gas appliance and/or its vent system. In cooler climates the vent should be enclosed inside the chase.

**NOTICE:** Treatment of ceiling firestops and wall shield firestops and construction of the chase may vary with the type of building. These instructions are not substitutes for the requirements of local building codes. Therefore, you **MUST** check local building codes to determine the requirements to these steps.

Chases should be constructed in the manner of all outside walls of the home to prevent cold air drafting problems. The chase should not break the outside building envelope in any manner.

Walls, ceiling, base plate and cantilever floor of the chase should be insulated. Vapor and air infiltration barriers should be installed in the chase as per regional codes for the rest of the home. Additionally, in regions where cold air infiltration may be an issue, the inside surfaces may be sheetrocked and taped for maximum air tightness.

To further prevent drafts, the wall shield and ceiling firestops should be caulked with caulk with a minimum of

300°F continuous exposure rating to seal gaps. Gas line holes and other openings should be caulked with caulk with a minimum of 300°F continuous exposure rating or stuffed with unfaced insulation. If the appliance is being installed on a cement surface, a layer of plywood may be placed underneath to prevent conducting cold up into the room.

## C. Clearances

**NOTICE:** Install appliance on hard metal or wood surfaces extending full width and depth. **DO NOT** install directly on carpeting, vinyl, tile or any combustible material other than wood.

**WARNING! Risk of Fire!** Maintain specified air space clearances to appliance and vent pipe:

- Insulation and other materials must be secured to prevent accidental contact.
- The chase must be properly blocked to prevent blown insulation or other combustibles from entering and making contact with fireplace or chimney.
- Failure to maintain airspace may cause overheating and a fire.

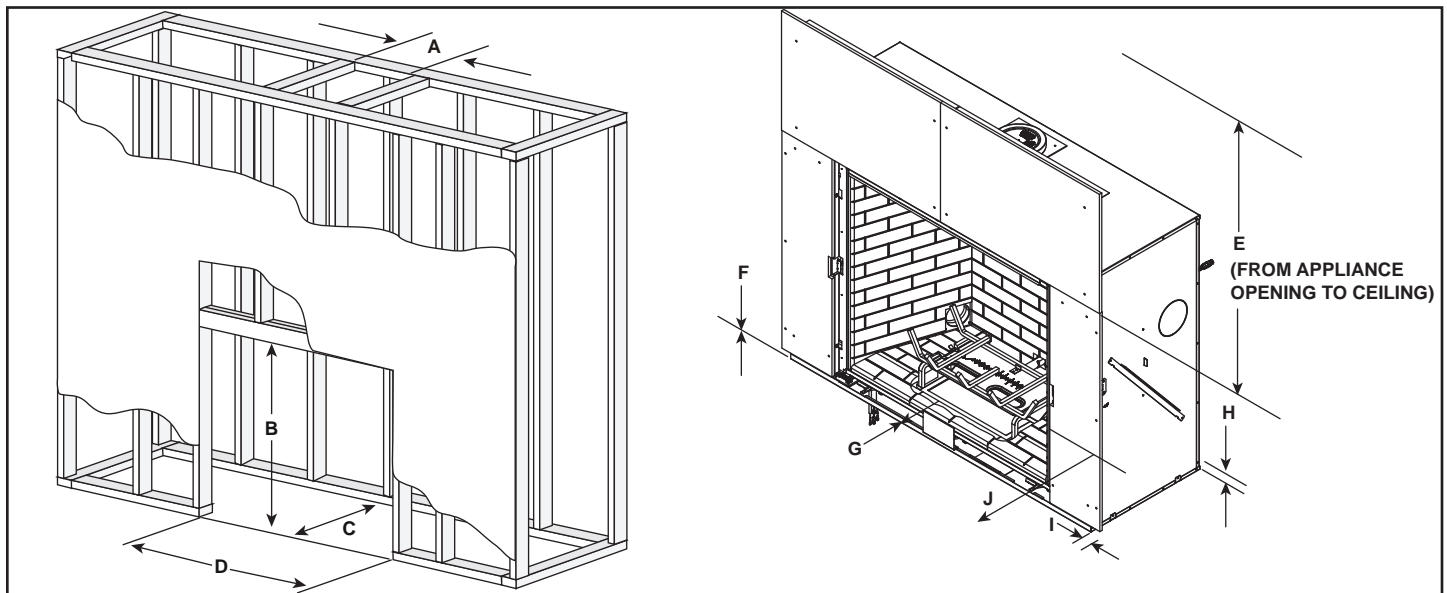

		* MINIMUM FRAMING DIMENSIONS									
		A	B	C	D	E	F	G	H	I	J
		Rough Opening (Vent Pipe)	Rough Opening (Height)	Rough Opening (Depth)	Rough Opening (Width)	Clearance to Ceiling	Combustible Floor	Combustible Flooring	Behind Appliance	Sides of Appliance	Front of Appliance
TRUE-36	Inches	10	56	24	59-1/2	52	0	See Section 5.E.	1	1	36
	Millimeters	254	1422	610	1511	1321	0		25	25	914
TRUE-42	Inches	10	61	24	65-9/16	52	0		1	1	36
	Millimeters	254	1549	610	1665	1321	0		25	25	914
TRUE-50	Inches	10	65	24	73-9/16	52	0		1	1	36
	Millimeters	254	1651	610	1868	1321	0		25	25	914

\* Adjust framing dimensions for interior sheathing (such as sheetrock)

Figure 5.2 Clearances to Combustibles

### Non-Combustible Zone

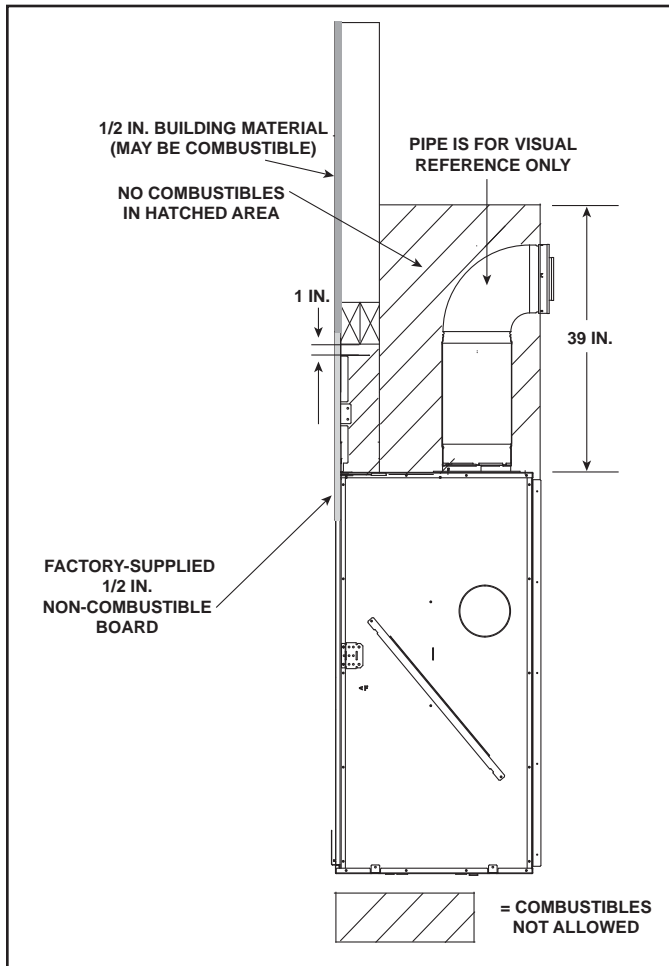

Figure 5.3 Non-Combustible Zone

### D. Mantel and Wall Projections

**WARNING! Risk of Fire!** Comply with all minimum clearances as specified. Framing or finishing material closer than the minimums listed must be constructed entirely of non-combustible materials (i.e., steel studs, concrete board, etc).

When installing a mantel, provisions must be made in order to secure the mantel to the adjacent framing materials. For example, lintel brackets or lag bolts may be considered for this purpose.

### Combustible Mantel Legs or Wall Projections

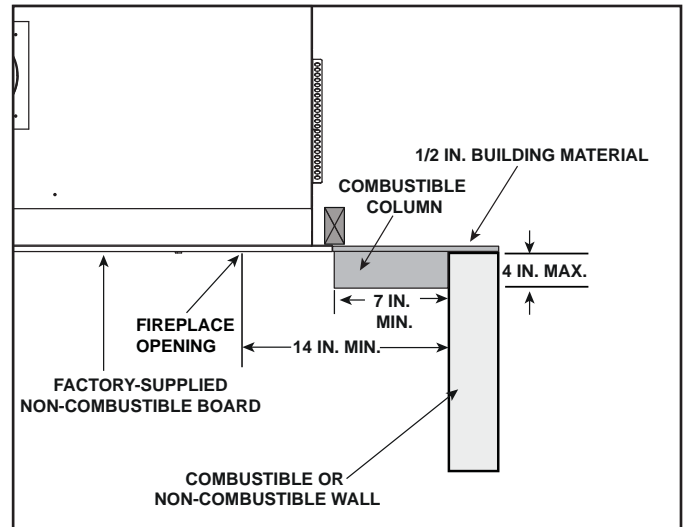

Figure 5.4 Combustible Mantel Leg and Wall Projections

### Non-Combustible Mantel Legs or Wall Projections

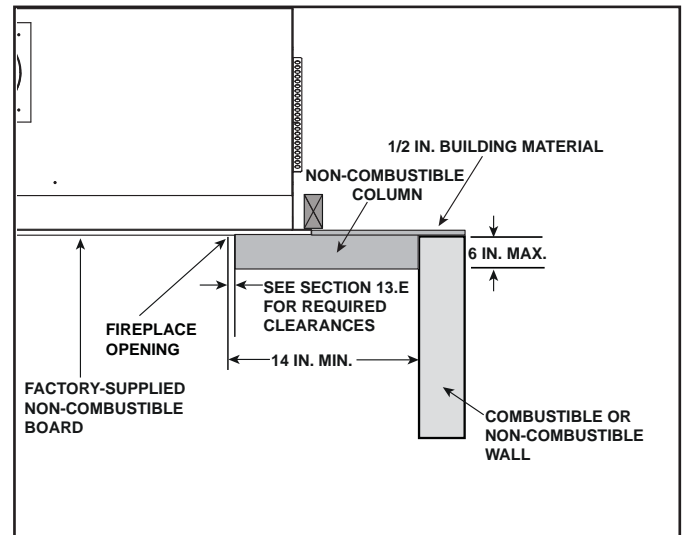

Figure 5.5 Non-Combustible Mantel Leg and Wall Projections

### Combustible Mantel Projections

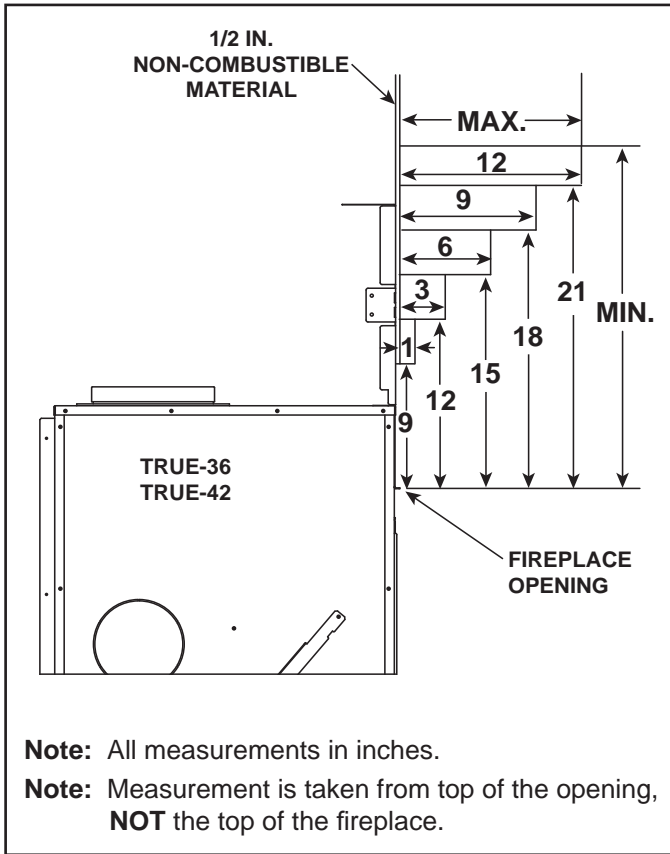

Figure 5.6 Combustible Mantel Allowance - TRUE-36, TRUE-42

### Non-Combustible Mantel Projections

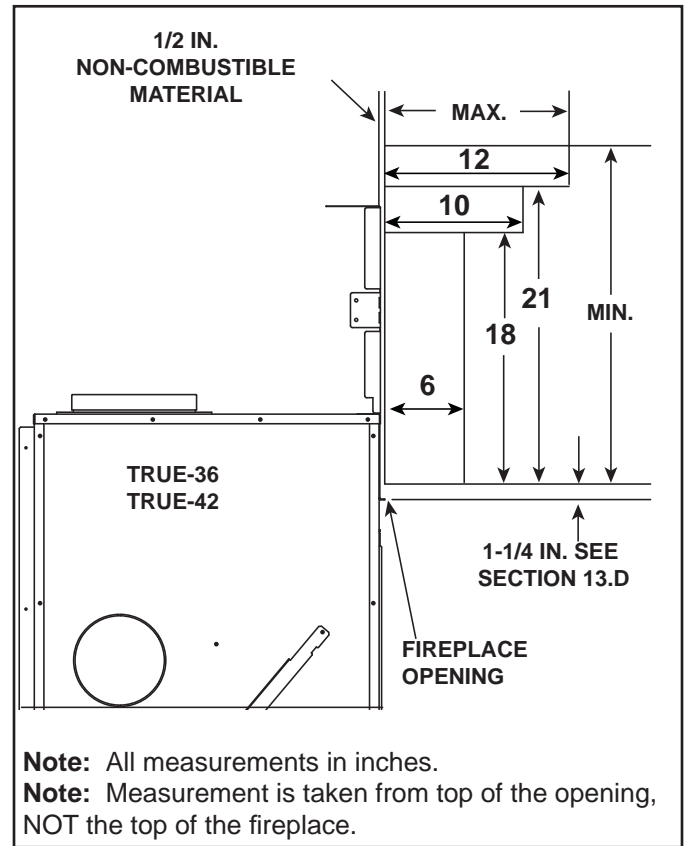

Figure 5.8 Non-Combustible Mantel Allowance - TRUE-36, TRUE-42

### Combustible Mantel Projections

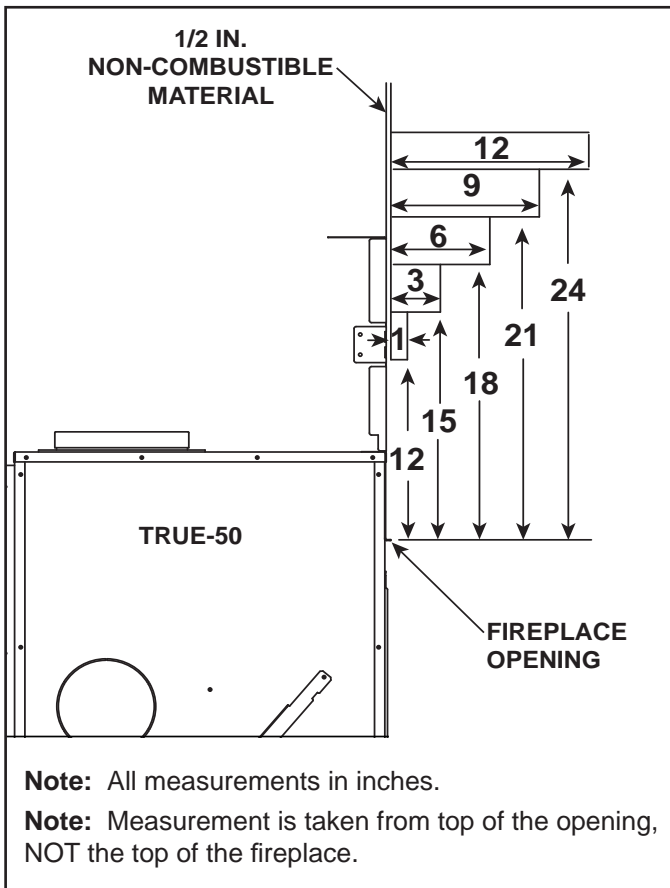

Figure 5.7 Combustible Mantel Allowance - TRUE-50

### Non-Combustible Mantel Projections

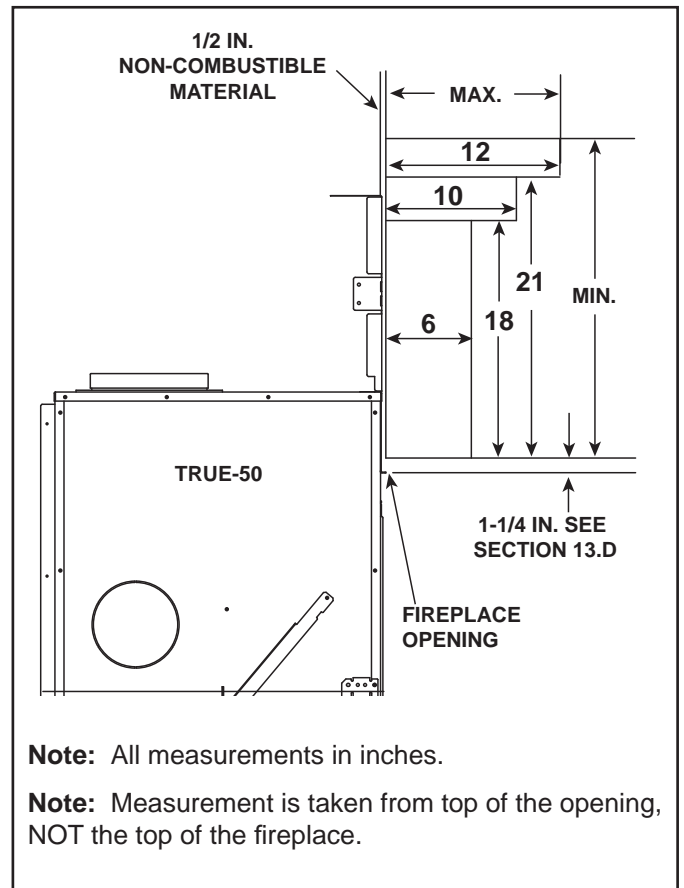

Figure 5.9 Non-Combustible Mantel Allowance - TRUE-50

## E. Hearth Extension

➔ **WARNING! Risk of Fire!** Non-combustible hearth extension may be required when appliance is installed on combustible surface.

- Hearth extension must be non-combustible and serves to protect combustible floors in front of appliance. See Figure 5.11.
- The base of the fireplace may sit on a combustible surface. See Figure 5.11. The area in front of the appliance must be protected by a non-combustible hearth extension, unless the appliance is raised a minimum of three inches above the combustible floor or hearth. See Figure 5.11 and Figure 5.12.

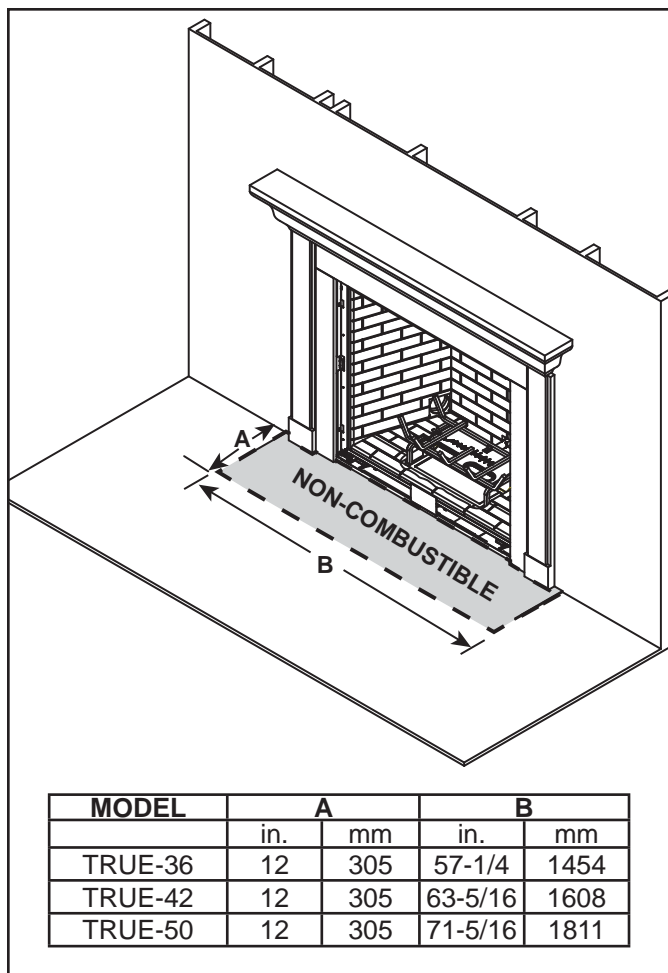

Figure 5.10 Non-Combustible Hearth Extension Dimensions

**NOTICE: DO NOT** install a hearth that is greater than one inch thick. Hearth will interfere with installation of glass assembly. Total hearth height must not exceed one inch from bottom of appliance when appliance is installed directly on floor (including mortar, backer material, etc.)

If a hearth greater than one inch in thickness is desired, the appliance must be raised by the equivalent height to ensure that the hearth extension does not interfere with the installation of the glass assembly required for fireplace operation. See Figure 5.11.

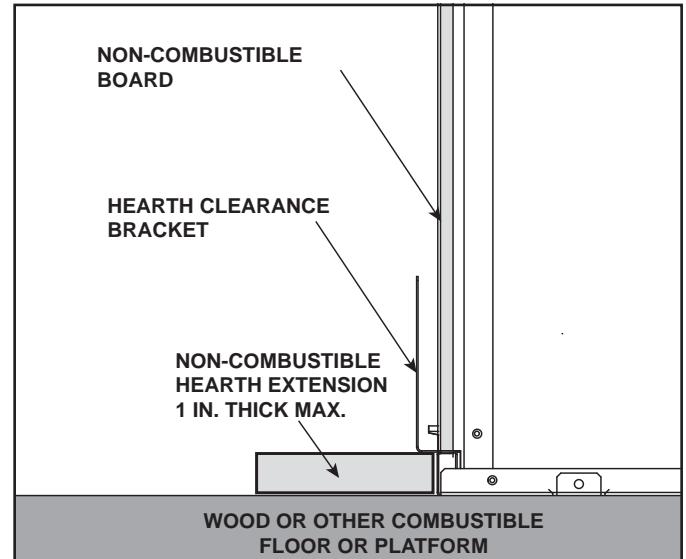

Figure 5.11 Appliance Installed on Combustible Surface  
Non-Combustible Hearth Extension REQUIRED.

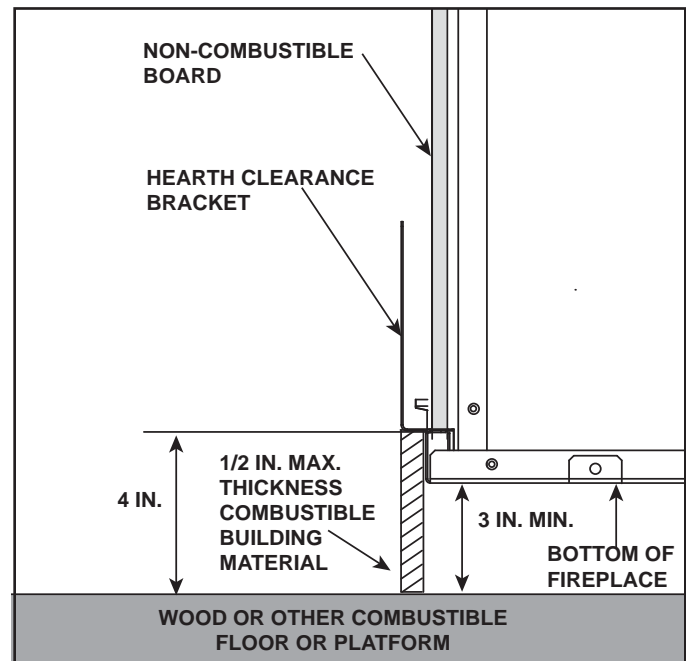

Figure 5.12 Appliance Raised a Minimum of 3 Inches Above  
Combustible Surface.  
Non-Combustible Hearth Extension NOT REQUIRED.

# 6 Termination Locations

## A. Vent Termination Minimum Clearances

**WARNING**

Fire Risk.  
Maintain vent clearance to combustibles as specified.

- DO NOT** pack air space with insulation or other materials.

Failure to keep insulation or other materials away from vent pipe may cause overheating and fire.

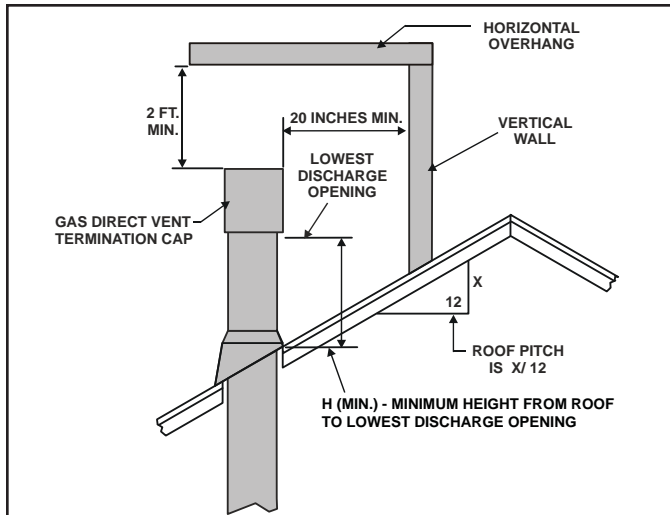

Roof Pitch	H (Min.) Ft.
Flat to 6/12.....	1.0*
Over 6/12 to 7/12.....	1.25*
Over 7/12 to 8/12.....	1.5*
Over 8/12 to 9/12.....	2.0*
Over 9/12 to 10/12.....	2.5
Over 10/12 to 11/12.....	3.25
Over 11/12 to 12/12.....	4.0
Over 12/12 to 14/12.....	5.0
Over 14/12 to 16/12.....	6.0
Over 16/12 to 18/12.....	7.0
Over 18/12 to 20/12.....	7.5
Over 20/12 to 21/12.....	8.0

\* 3 foot minimum in snow regions

**Figure 6.1 Minimum Height From Roof To Lowest Discharge Opening**

A	B
6 in. (minimum) up to 20 in. 152 mm/508 mm	18 in. minimum 457 mm
20 in. and over	0 in. minimum

\* If using decorative cap cover(s), this distance may need to be increased. Refer to the installation instructions supplied with the decorative cap cover.

\*\* In a staggered installation with both gas and wood or fuel oil terminations, the wood or fuel oil termination cap must be higher than the gas termination cap.

**Figure 6.2 Staggered Termination Caps**

**NOTICE: TRUE-50 Models Only**

Horizontal vent terminations are NOT approved for installation with vinyl siding or vinyl soffits. Permanent damage to vinyl siding or vinyl soffits may occur.

**NOTICE: TRUE-36 and TRUE-42 Only:**

Horizontal vent terminations ARE approved for installation with vinyl siding and/or vinyl soffits provided the VPK-DV (vinyl protector kit) is installed. Permanent damage to vinyl siding or vinyl soffits may occur.



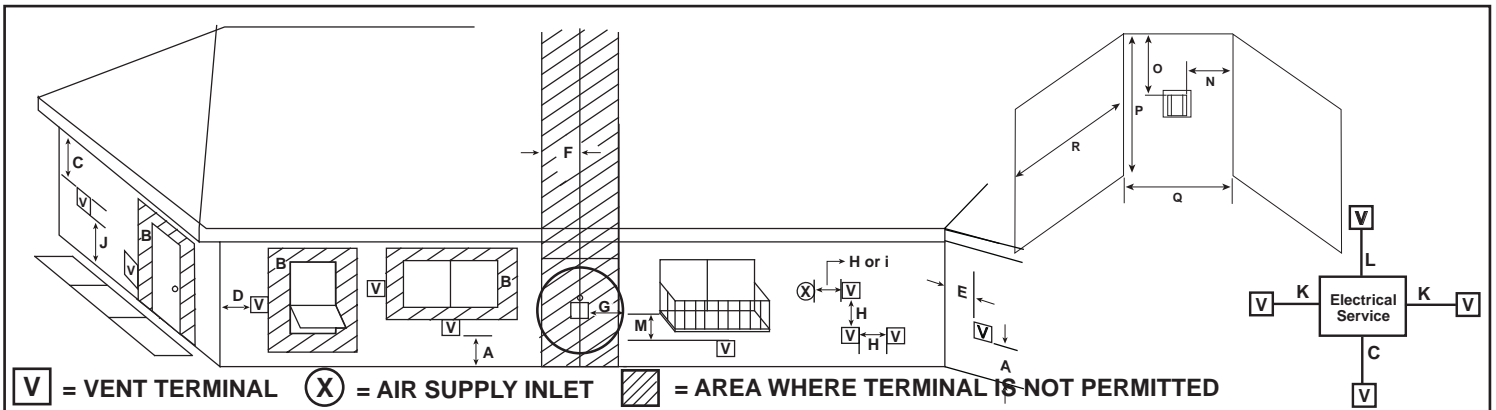

**V** = VENT TERMINAL    **X** = AIR SUPPLY INLET    [Hatched] = AREA WHERE TERMINAL IS NOT PERMITTED

- A = 12 inches.....clearances above grade, veranda, porch, deck or balcony
  - B = 12 inches.....clearance to window or door that may be opened, or to permanently closed window
  - C = 18 inches.....clearance below an unventilated/ventilated soffit with non-vinyl siding
  - = 18 inches.....clearance below an unventilated/ventilated soffit with vinyl siding. Requires a vinyl protector kit (VPK-DV). TRUE-50 is not approved for use with vinyl siding or vinyl soffits.
  - = 42 inches.....clearance below a vinyl soffit with non-vinyl siding. TRUE-50 is not approved for use with vinyl siding or vinyl soffits.
  - = 42 inches.....clearance below a vinyl soffit with vinyl siding. Requires a vinyl protector kit (VPK-DV). TRUE-50 is not approved for use with vinyl siding or vinyl soffits.
  - D = 6 inches.....clearance to outside corner
  - E = 6 inches.....clearance to inside corner
  - F = 3 ft. (Canada).....not to be installed above a gas meter/regulator assembly within 3 feet horizontally from the center-line of the regulator
  - G = 3 ft.....clearance to gas service regulator vent outlet
  - H = 12 inches.....clearance to non-mechanical (unpowered) air supply inlet, combustion air inlet or direct-vent termination
  - i = 3 ft. (U.S.A.)  
6 ft. (Canada).....clearance to a mechanical (powered) air supply inlet
- All mechanical air intakes within 10 feet of a termination cap must be a minimum of 3 feet below termination.
- J = 7 ft..... On public property: clearance above paved sidewalk or a paved driveway.
- A vent shall not terminate directly above a sidewalk or paved driveway which is located between two single family dwellings and serves both dwellings.
- K = 6 inches.....clearance from sides of electrical service
  - L = 12 inches.....clearance above electrical service  
Location of the vent termination must not interfere with access to the electrical service.
- M = 24 inches ..... clearance under veranda, porch, deck, balcony or overhang
  - 42 inches ..... vinyl or composite overhang
- Permitted when veranda, porch, deck or balcony is fully open on a minimum of 2 sides beneath the floor.

### Covered Alcove Applications

(Spaces open only on one side and with an overhang)

**TRUE-50 is not approved for use with vinyl siding or vinyl soffits.**

- N = 6 inches .....non-vinyl sidewalls
- 12 inches .....vinyl sidewalls
- O = 18 inches .....clearance below an unventilated/ventilated soffit with non-vinyl siding
- = 18 inches.....clearance below an unventilated/ventilated soffit with vinyl siding. Requires a vinyl protector kit (VPK-DV).
- = 42 inches.....clearance below a vinyl soffit with non-vinyl siding
- = 42 inches.....clearance below a vinyl soffit with vinyl siding. Requires a vinyl protector kit (VPK-DV).

P = 8 ft.

	$Q_{MIN}$	$R_{MAX}$
1 cap	3 feet	2 x $Q_{ACTUAL}$
2 caps	6 feet	1 x $Q_{ACTUAL}$
3 caps	9 feet	2/3 x $Q_{ACTUAL}$
4 caps	12 feet	1/2 x $Q_{ACTUAL}$
$Q_{MIN} = \# \text{ termination caps} \times 3$ $R_{MAX} = (2 / \# \text{ termination caps}) \times Q_{ACTUAL}$		

Measure vertical clearances from this surface.

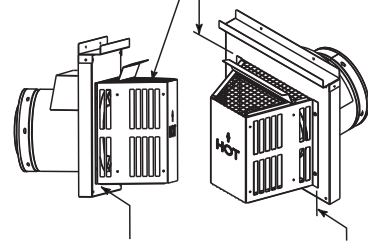

Measure horizontal clearances from this surface.

**CAUTION! Risk of Burns!** Termination caps are HOT, consider proximity to doors, traffic areas or where people may pass or gather (sidewalk, deck, patio, etc.). Listed cap shields available. Contact your dealer.

- Local codes or regulations may require different clearances.
- Vent system termination is **NOT** permitted in screened porches.
- Vent system termination is permitted in porch areas with two or more sides open.
- Hearth & Home Technologies assumes no responsibility for the improper performance of the appliance when the venting system does not meet these requirements.
- Vinyl protection kits are required for use with vinyl siding.

**Figure 6.3 Minimum Clearances for Termination**

# 7 Vent Information and Diagrams

## A. Approved Pipe

This appliance is approved for use with Hearth & Home Technologies DVP venting systems. Refer to Section 16.B for vent component information.

**DO NOT** mix pipe, fittings or joining methods from different manufacturers.

The pipe is tested to be run inside an enclosed wall. There is no requirement for inspection openings at each joint within the wall.

**WARNING! Risk of Fire or Asphyxiation.** This appliance requires a separate vent. **DO NOT** vent to a pipe serving a separate solid fuel burning appliance.

## B. Vent Table Key

The abbreviations listed in this vent table key are used in the vent diagrams.

Symbol	Description
V <sub>1</sub>	First section (closest to appliance) of vertical length
V <sub>2</sub>	Second section of vertical length
H <sub>1</sub>	First section (closest to appliance) of horizontal length
H <sub>2</sub>	Subsequent sections of horizontal length

## C. Use of Elbows

Diagonal runs have both vertical and horizontal vent aspects when calculating the effects. Use the rise for the vertical aspect and the run for the horizontal aspect (see Figure 7.1).

Two 45° elbows may be used in place of one 90° elbow. On 45° runs, one foot of diagonal is equal to 8-1/2 in. (216 mm) horizontal run and 8-1/2 in. (216 mm) vertical run. A length of straight pipe is allowed between two 45° elbows. See Figure 7.1.

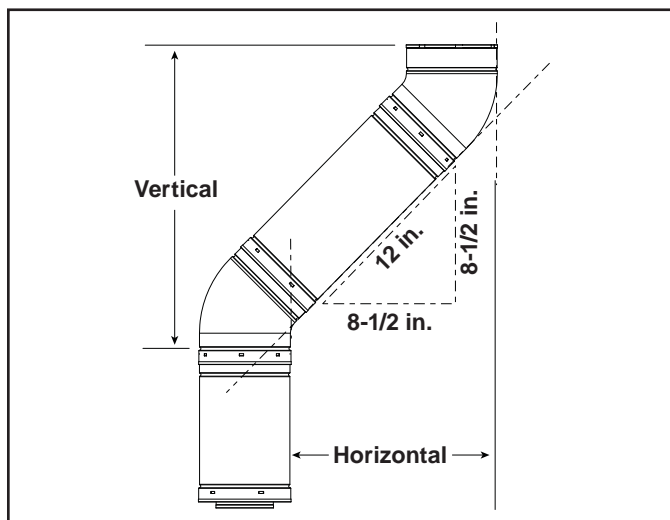

Figure 7.1

## D. Measuring Standards

Vertical and horizontal measurements listed in the vent diagrams were made using the following standards.

- Pipe measurements are shown using the effective length of pipe (see Figure 7.2).
- Horizontal terminations are measured to the outside mounting surface (flange of termination cap) (see Figure 6.3).
- Vertical terminations are measured to bottom of termination cap.
- Horizontal pipe installed level with no rise.

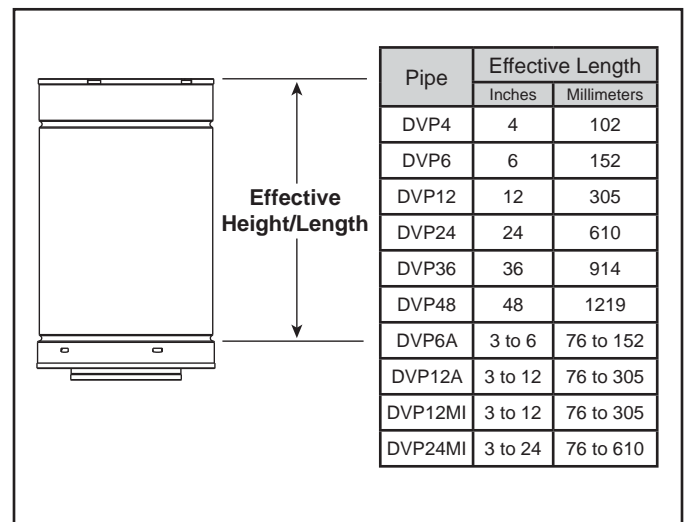

Figure 7.2 DVP Pipe Effective Length

## E. Vent Diagrams

**WARNING! Risk of Fire.** This appliance requires a minimum of 24 inches of vertical venting before attaching any elbow to the appliance. **DO NOT** attach elbow directly to the appliance.

General Rules:

- This appliance is approved for use with Hearth & Home Technologies DVP venting systems ONLY.
- When penetrating a combustible wall, a wall shield firestop must be installed.
- When penetrating a combustible ceiling, a ceiling firestop must be installed.
- This appliance requires a minimum of 24 inches of vertical pipe attached directly to the appliance starting collar before attaching a 90 degree or 45 degree elbow.

# 1. Top Vent - Horizontal Termination

## One Elbow

**Note:** Flue restrictor is permitted ONLY on 30 ft. minimum vertical runs with no elbows.

### WARNING! Risk of Fire!

- TRUE-36(NG/LP), TRUE-42(NG), and TRUE-50(NG/LP) models require a minimum of 24 inches of vertical venting before attaching any elbow to the appliance.
- TRUE-42(LP) model requires a minimum of 36 inches of vertical venting before attaching any elbow to the appliance.

**DO NOT attach elbow directly to the appliance.**

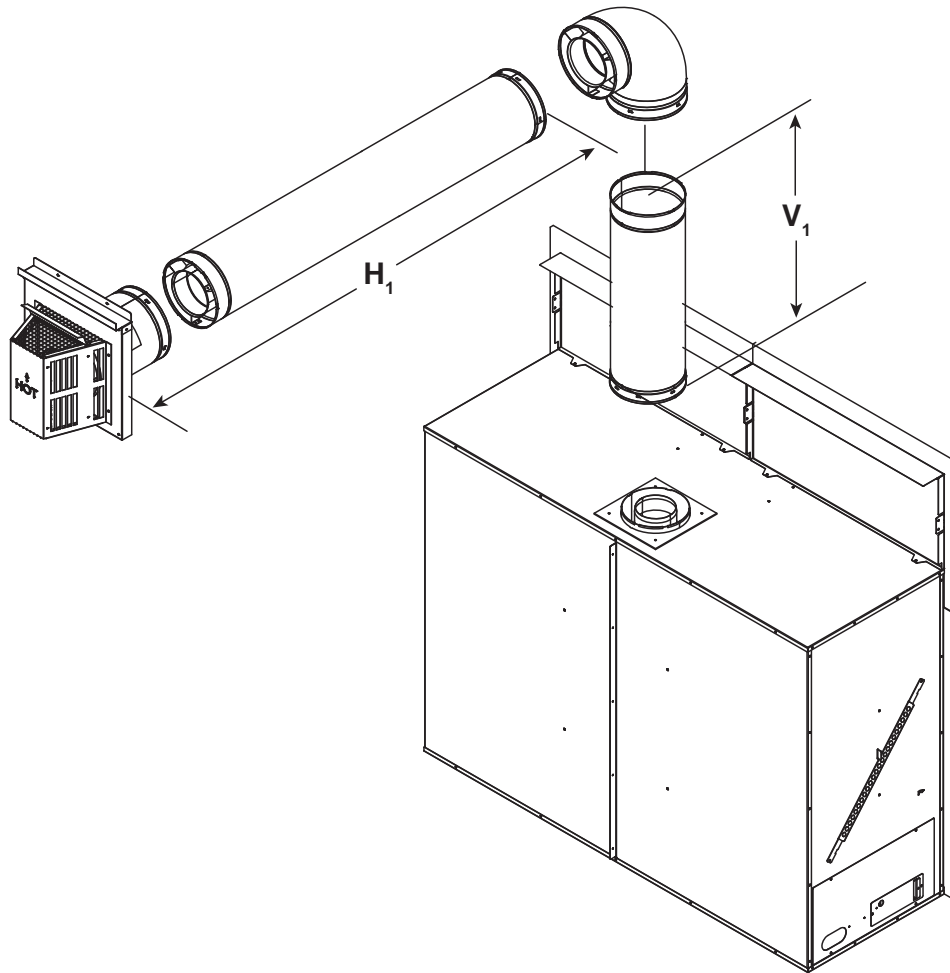

TRUE-36 (NG/LP), TRUE-42 (NG), TRUE-50 (NG/LP)			
V <sub>1</sub> Minimum		H <sub>1</sub> Maximum	
2 ft	610 mm	7 in*	178 mm
3 ft	914 mm	2 ft	610 mm
4 ft	1.2 m	4 ft	1.2 m
5 ft	1.5 m	9 ft	2.7 m
6 ft	1.8 m	12 ft	3.7 m
7 ft	2.1 m	14 ft	4.3 m
10 ft	3.0 m	20 ft	6.1 m
20 ft	6.1 m	40 ft	12.2 m
After V <sub>1</sub> = 6 ft then H <sub>1</sub> = 2 x V ft Maximum V <sub>1</sub> + H <sub>1</sub> = 60 ft Maximum			
*when used with approved termination caps			

TRUE-42 (LP)			
V <sub>1</sub> Minimum		H <sub>1</sub> Maximum	
3 ft	914 mm	10 in.	254 mm
4 ft	1.2 m	4 ft	1.2 m
5 ft	1.5 m	9 ft	2.7 m
6 ft	1.8 m	12 ft	3.7 m
7 ft	2.1 m	14 ft	4.3 m
10 ft	3.0 m	20 ft	6.1 m
20 ft	6.1 m	40 ft	12.2 m
After V <sub>1</sub> = 6 ft then H <sub>1</sub> = 2 x V ft Maximum V <sub>1</sub> + H <sub>1</sub> = 60 ft Maximum			
*when used with approved termination caps			

Figure 7.3

## Two Elbows

**Note:** Flue restrictor is permitted ONLY on 30 ft. minimum vertical runs with no elbows.

### **WARNING! Risk of Fire!**

- TRUE-36(NG/LP), TRUE-42(NG/LP) and TRUE-50(NG/LP) models require a minimum of 36 inches of vertical venting before attaching any elbow to the appliance for the venting configuration in Figure 7.4.

**DO NOT attach elbow directly to the appliance.**

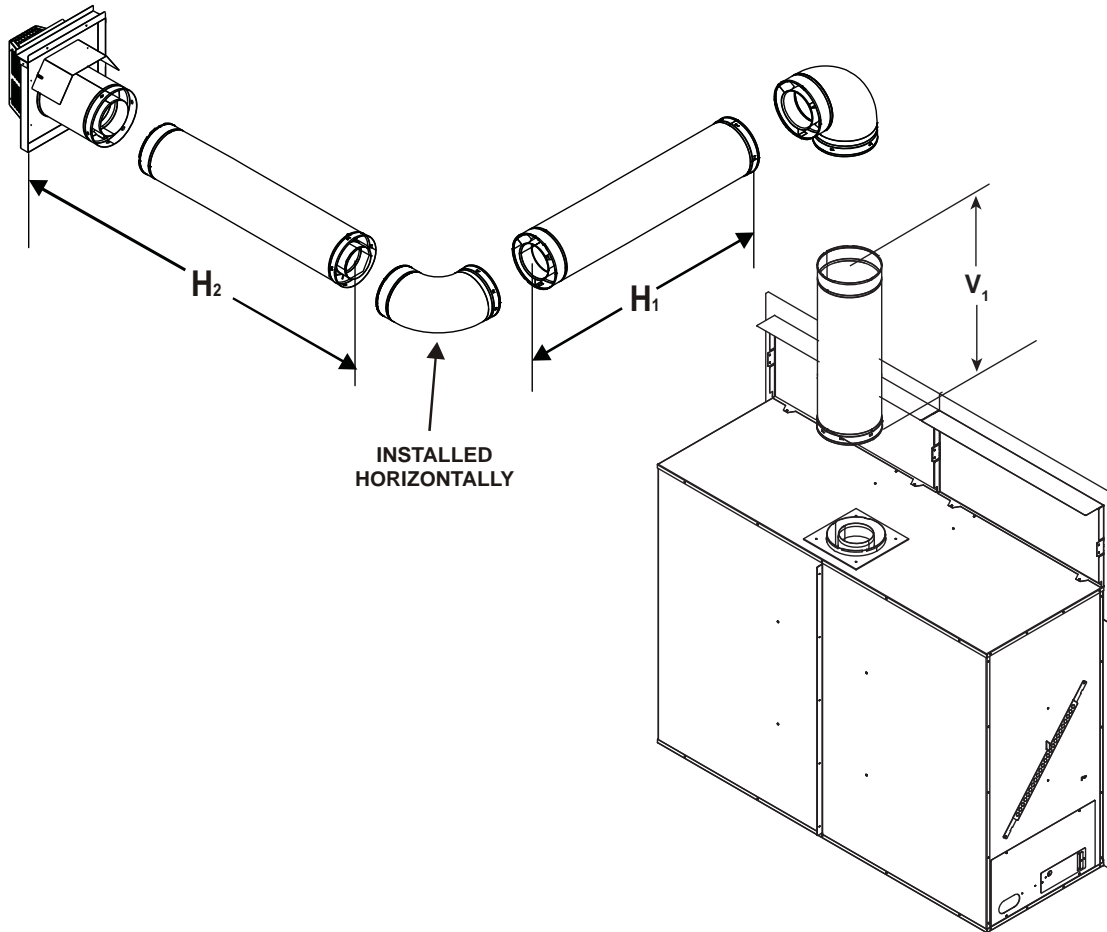

TRUE-36 (NG/LP), TRUE-42 (NG/LP), TRUE-50 (NG/LP)			
$V_1$ Minimum		$H_1 + H_2$	
3 ft	914 mm	18 in	457 mm
4 ft	1.2 m	3 ft	914 mm
5 ft	1.5 m	7 ft	2.1 m
6 ft	1.8 m	10 ft	3.0 m
7 ft	2.1 m	14 ft	4.3 m
8 ft	2.4 m	16 ft	4.9 m
9 ft	2.7 m	18 ft	5.5 m
10 ft	3.0 m	20 ft	6.1 m
$V_1 + H_1 + H_2 = 60$ ft Maximum $H_1 + H_2 = 20$ ft Maximum			

Figure 7.4

# 1. Top Vent - Horizontal Termination - (continued)

## Three Elbows

**Note:** Flue restrictor is permitted ONLY on 30 ft. minimum vertical runs with no elbows.

**WARNING! Risk of Fire!**

- TRUE-36(NG/LP), TRUE-42(NG/LP) and TRUE-50 (NG/LP) models require a minimum of 24 inches of vertical venting before attaching any elbow to the appliance.

**DO NOT attach elbow directly to the appliance.**

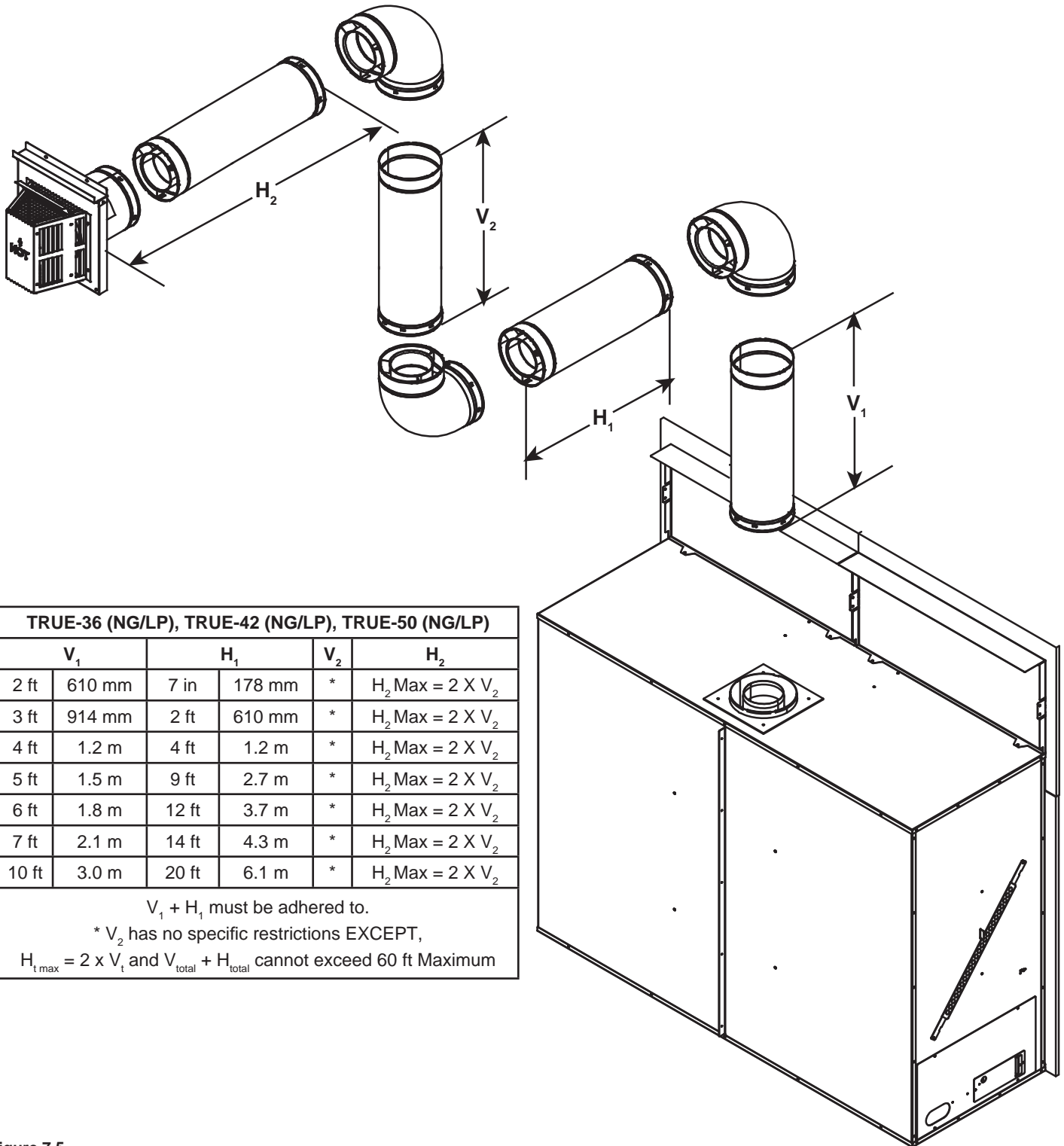

TRUE-36 (NG/LP), TRUE-42 (NG/LP), TRUE-50 (NG/LP)					
	V <sub>1</sub>	H <sub>1</sub>		V <sub>2</sub>	H <sub>2</sub>
2 ft	610 mm	7 in	178 mm	*	H <sub>2</sub> Max = 2 X V <sub>2</sub>
3 ft	914 mm	2 ft	610 mm	*	H <sub>2</sub> Max = 2 X V <sub>2</sub>
4 ft	1.2 m	4 ft	1.2 m	*	H <sub>2</sub> Max = 2 X V <sub>2</sub>
5 ft	1.5 m	9 ft	2.7 m	*	H <sub>2</sub> Max = 2 X V <sub>2</sub>
6 ft	1.8 m	12 ft	3.7 m	*	H <sub>2</sub> Max = 2 X V <sub>2</sub>
7 ft	2.1 m	14 ft	4.3 m	*	H <sub>2</sub> Max = 2 X V <sub>2</sub>
10 ft	3.0 m	20 ft	6.1 m	*	H <sub>2</sub> Max = 2 X V <sub>2</sub>

V<sub>1</sub> + H<sub>1</sub> must be adhered to.  
 \* V<sub>2</sub> has no specific restrictions EXCEPT,  
 H<sub>t max</sub> = 2 x V<sub>t</sub> and V<sub>total</sub> + H<sub>total</sub> cannot exceed 60 ft Maximum

Figure 7.5

## 2. Top Vent - Vertical Termination

### No Elbow

**Note:** Flue restrictor is permitted ONLY on 30 ft. minimum vertical runs with no elbows.

$V_1 = 50 \text{ ft. Max. (15.2 m)}$   
 $V_1 = 2 \text{ ft. Min. (610 mm)}$

**NOTE:** Flue Restrictor ships in manual bag assembly.

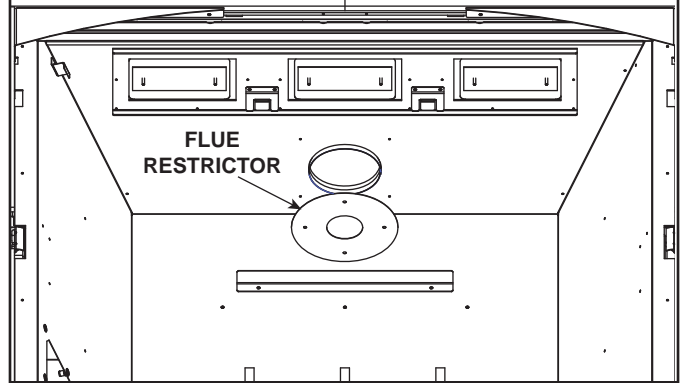

Figure 7.7 Flue Restrictor Installation

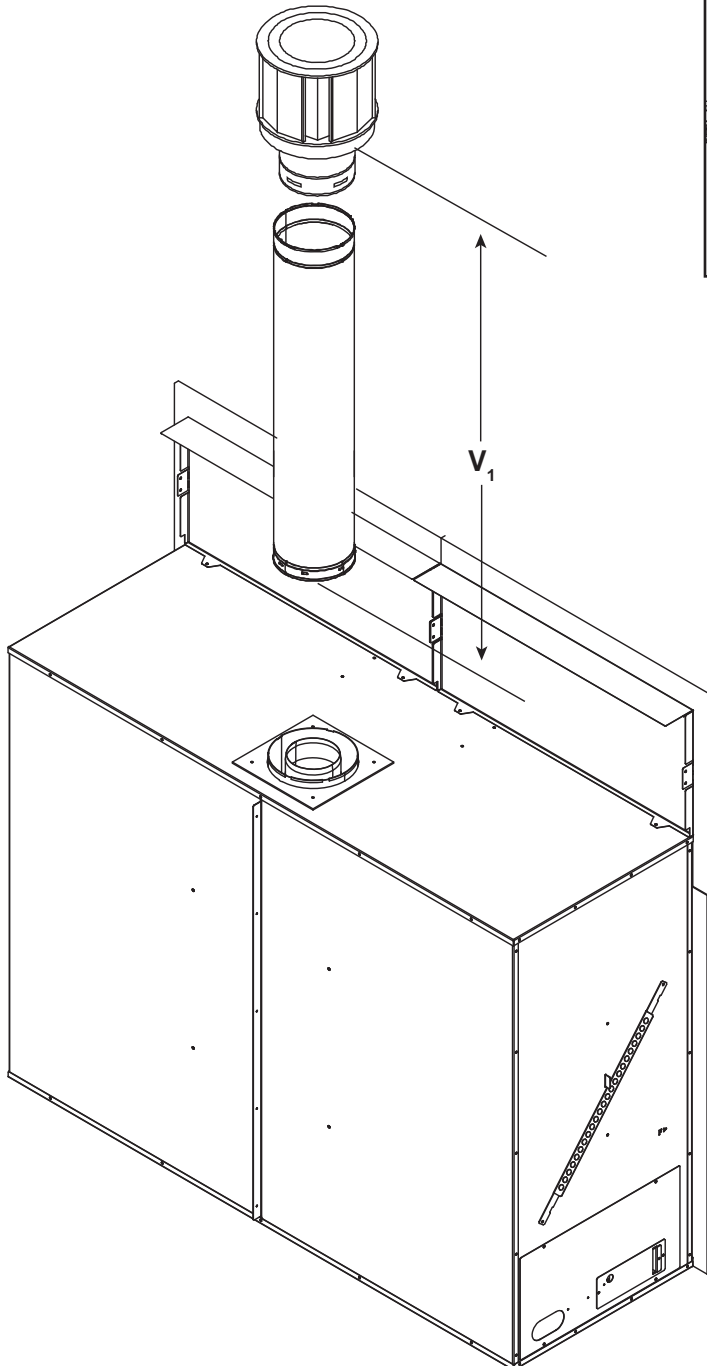

Figure 7.6

## 2. Top Vent - Vertical Termination - (continued)

### 2 ELBOWS

**Note:** Flue restrictor is permitted ONLY on 30 ft. minimum vertical runs with no elbows.

#### **WARNING! Risk of Fire!**

- TRUE-36(NG/LP), TRUE-42(NG/LP) and TRUE-50 (NG/LP) models require a minimum of 24 inches of vertical venting before attaching any elbow to the appliance.

**DO NOT attach elbow directly to the appliance.**

TRUE-36 (NG/LP), TRUE-42 (NG/LP), TRUE-50 (NG/LP)				
$V_1$		$H_1$		$V_2$
2 ft	610 mm	1 ft	305 mm	*
3 ft	914 mm	3 ft	914 mm	*
4 ft	1.2 m	4 ft	1.2 m	*
5 ft	1.5 m	9 ft	2.7 m	*
6 ft	1.8 m	12 ft	3.7 m	*

$V_1 + V_2 + H_1 = 50 \text{ ft (15.2 m) Max.}$   
 \*No specific restrictions on this value EXCEPT  
 $V_1 + V_2 + H_1$  cannot exceed 60 ft (18.3 m).  
 After  $V_1 = 6 \text{ ft}$ , then  $H_1 \text{ Max.} = V_1 \times 2$

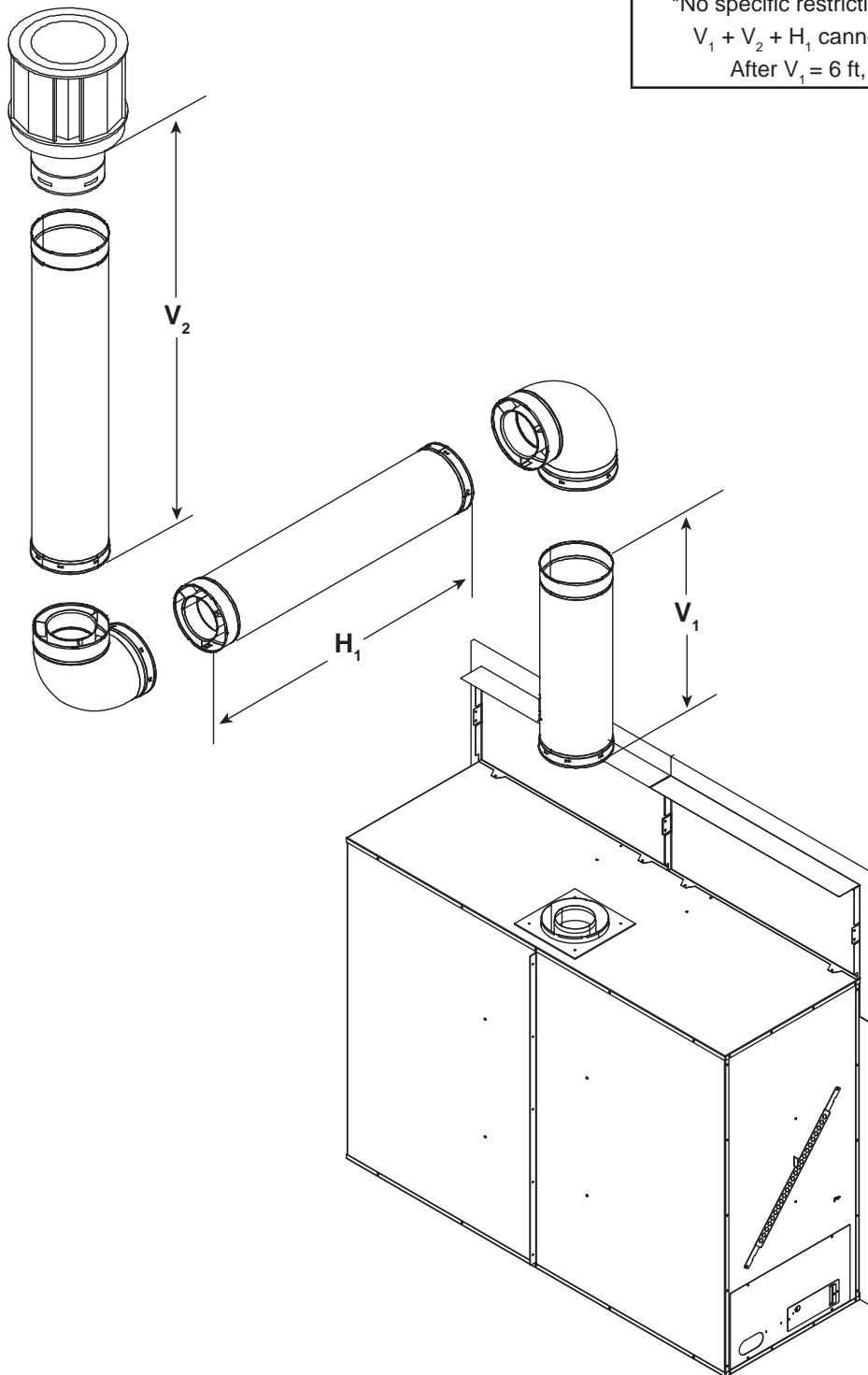

Figure 7.8

## 2. Top Vent - Vertical Termination - (continued)

### Three Elbows

**Note:** Flue restrictor is permitted ONLY on 30 ft. minimum vertical runs with no elbows.

**WARNING! Risk of Fire!**

- TRUE-36(NG/LP), TRUE-42(NG/LP) and TRUE-50 (NG/LP) models require a minimum of 24 inches of vertical venting before attaching any elbow to the appliance.

**DO NOT attach elbow directly to the appliance.**

TRUE-36 (NG/LP), TRUE-42 (NG/LP), TRUE-50 (NG/LP)						
	V <sub>1</sub>	H <sub>1</sub>	H <sub>2</sub>	V <sub>2</sub>	H <sub>t</sub> Max.	
2 ft	610 mm	*	*	**	7 in	178 mm
3 ft	914 mm	*	*	**	2 ft	610 mm
4 ft	1.2 m	*	*	**	4 ft	1.2 m
5 ft	1.5 m	*	*	**	8 ft	2.4 m
6 ft	1.8 m	*	*	**	12 ft	3.7 m
7 ft	2.1 m	*	*	**	14 ft	4.3 m
10 ft	3.0 m	*	*	**	20 ft	6.1 m

\*H<sub>1</sub> and H<sub>2</sub> has no specific restrictions EXCEPT, after V<sub>1</sub> = 6 ft, then H<sub>t</sub> Max = 2 x V<sub>1</sub>  
 \*\*V<sub>T</sub> + H<sub>T</sub> = 60 ft Max.

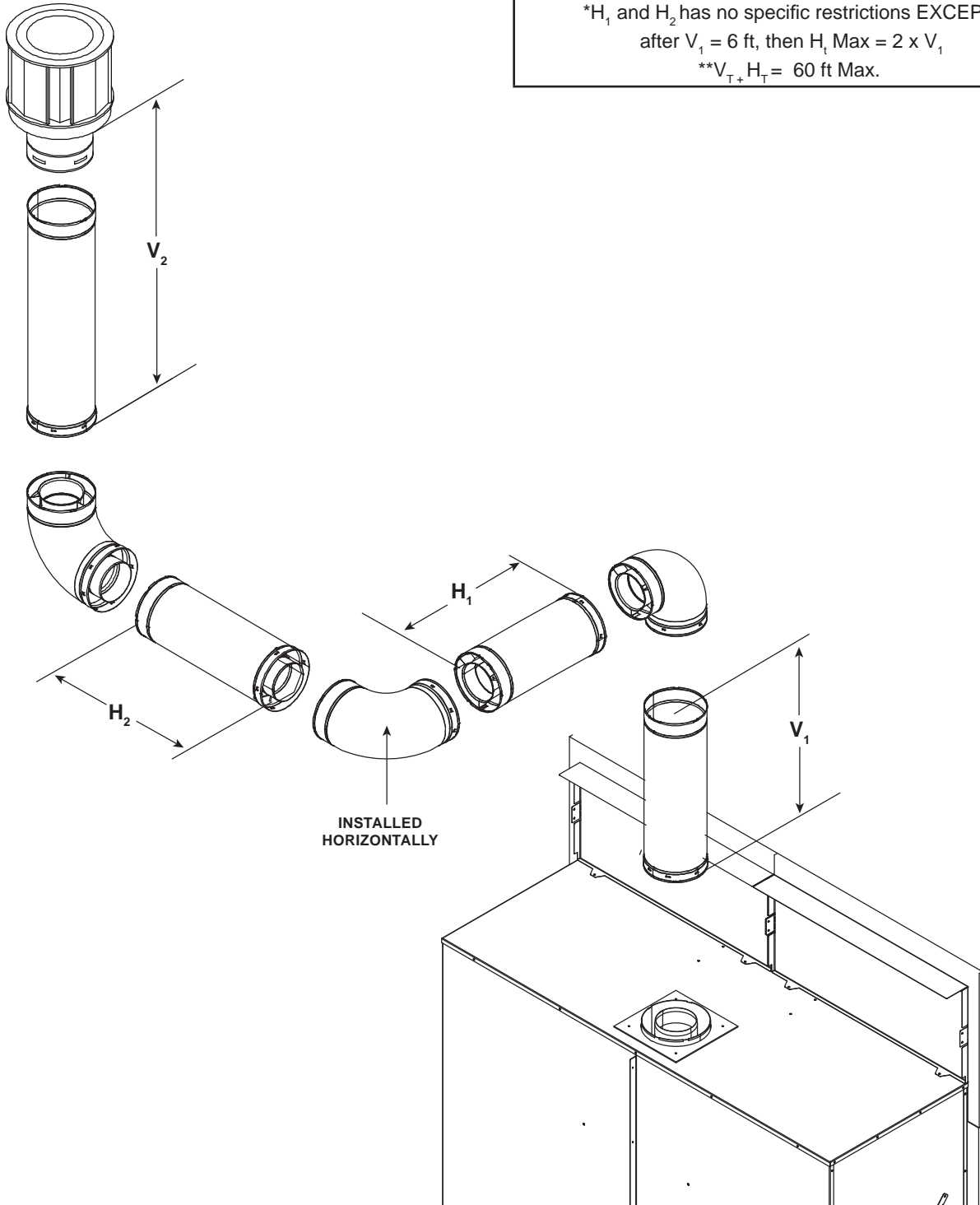

Figure 7.9



## F. PVK-80 and PVI-SLP Information

This section provides specific detail for installation of TRUE-36, TRUE-42, and TRUE-50 models with approved power vent kits. Follow instructions included with the PVK-80 or PVI-SLP power vent kits.

See Table 7.1 below for approved Power Venting options for TRUE models.

	PVK-80	PVI-SLP
TRUE-36	APPROVED	APPROVED
TRUE-42	APPROVED	APPROVED
TRUE-50	APPROVED	APPROVED

Table 7.1

**WARNING! Risk of Fire!** Use ONLY Hearth & Home Technologies-approved power venting systems with this appliance. Use of power venting systems not approved by Hearth & Home Technologies may cause fireplace to overheat.

The power vent draft flow must be adjusted and set per the specifications in Table 7.2. Refer to the instructions provided with the PVK-80 and PVI-SLP for more specific information.

**PVK-80:** The exhaust control lever reduces the draft as it is opened. Open the exhaust control lever to FULL OPEN. See Figure 7.10. Secure the exhaust control lever to the power vent housing with the sheet metal screw.

**PVI-SLP:** The baffle adjustment is measured using the holes on the indicator bar of the PVI-SLP baffle. This bar raises as the baffle is opened and lowers as the baffle is closed. Adjust the baffle by turning the screw located in the motor enclosure. See Figure 7.11 and 7.12.

**WARNING! Risk of Explosion!** Follow instructions to set draft flow. Incorrect setting may impair burner performance and/or cause delayed ignition.

	PVK-80 Exhaust Control Lever	PVI-SLP Baffle Adjustment Setting
TRUE-36	FULL OPEN	3 Holes Visible
TRUE-42	FULL OPEN	3 Holes Visible
TRUE-50	FULL OPEN	3 Holes Visible

Table 7.2



Figure 7.10 PVK-80 Control Lever Adjustment - Open

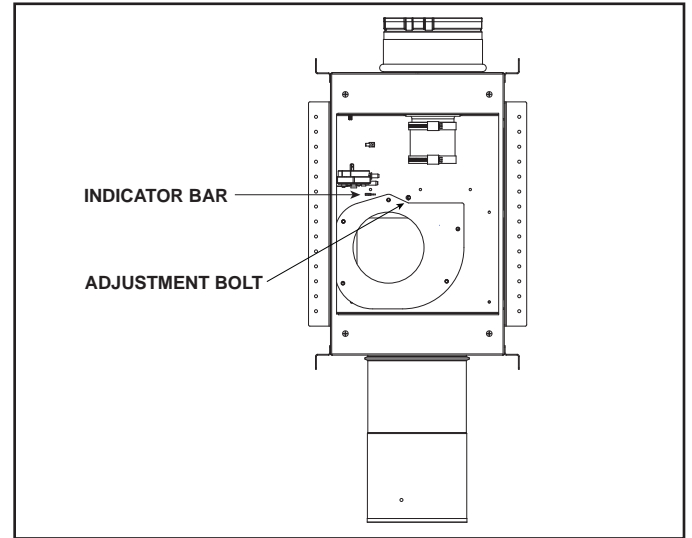

Figure 7.11 Baffle Adjustment Location - PVI-SLP

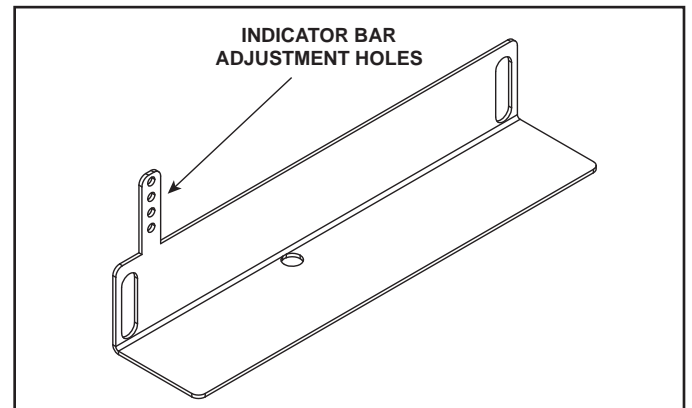

Figure 7.12 Baffle Adjustment - PVI-SLP

# 8 Vent Clearances and Framing

## A. Pipe Clearances to Combustibles

**WARNING! Risk of Fire!** Maintain air space clearance to vent. **DO NOT** pack insulation or other combustibles:

- Between ceiling firestops
- Between wall shield firestops
- Around vent system

Failure to keep insulation or other material away from vent pipe may cause overheating and fire.

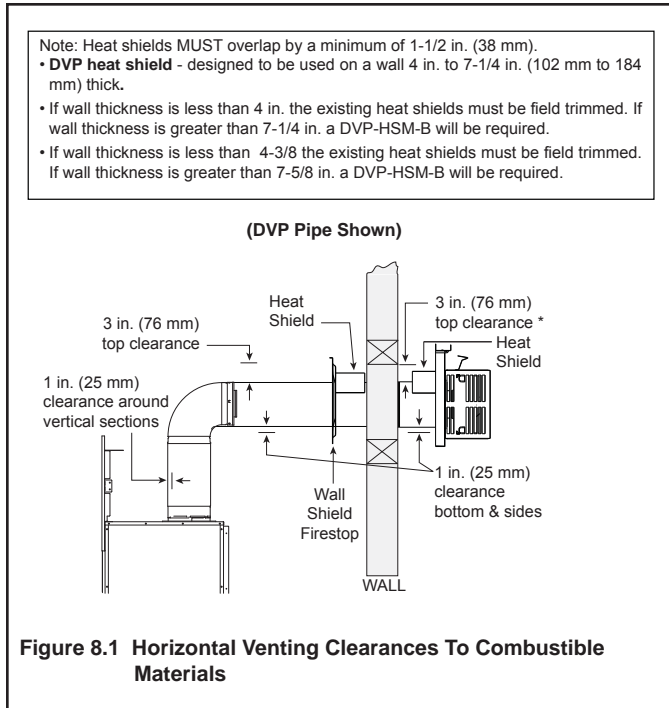

## B. Wall Penetration Framing

### Combustible Wall Penetration

Whenever a combustible wall is penetrated, you must frame a hole for the wall shield firestop(s). The wall shield firestop maintains minimum clearances and prevents cold air infiltration.

- The opening must be framed on all four sides using the same size framing materials as those used in the wall construction.
- DVP pipe - A wall shield firestop is required on one side only on interior walls. If your local inspector requires a wall shield firestop on both sides, then both wall shield firestops must have a heat shield (refer to Section 16.B.) attached to them.
- See Section 10.H. for information for regarding the installation of a horizontal termination cap.

### Non-Combustible Wall Penetration

If the hole being penetrated is surrounded by non-combustible materials such as concrete, a hole with diameter one inch greater than the pipe is acceptable.

Whenever a non-combustible wall is penetrated, the wall shield firestop is only required on one side and no heat shield is necessary.

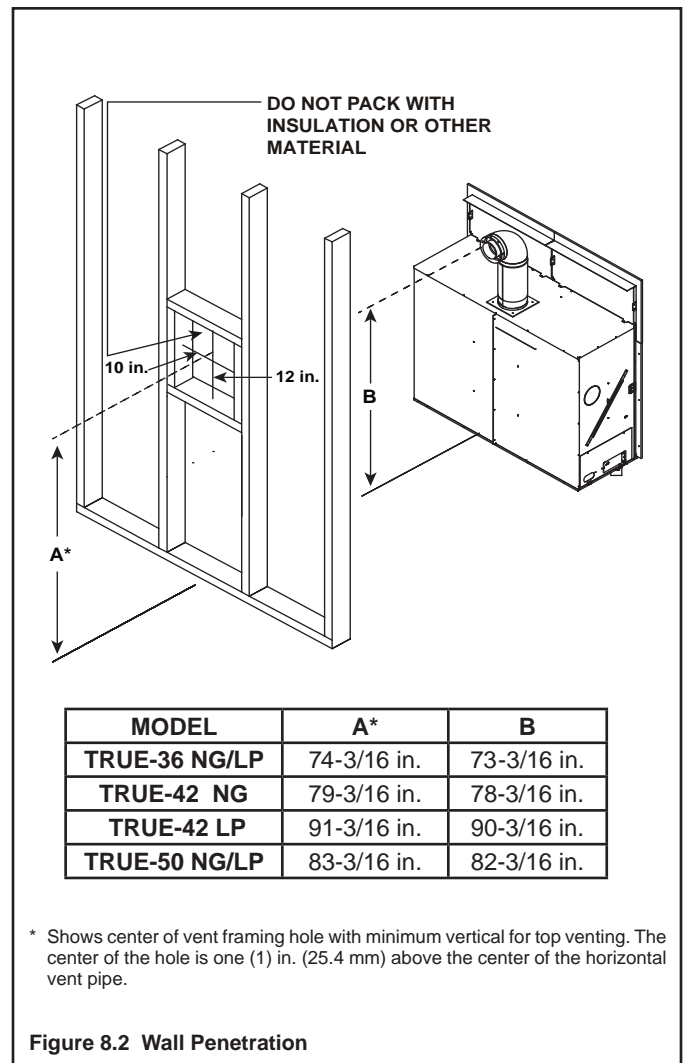

### C. Install the Ceiling Firestop

A ceiling firestop **MUST** be used between floors and attics.

- **DVP pipe only** - Frame an opening 10 in. by 10 in. (254 mm by 254 mm) whenever the vent penetrates a ceiling/floor (see Figure 8.3).
- Frame the area with the same sized lumber as used in ceiling/floor joist.
- The ceiling firestop may be installed above or below the ceiling joists when installed with an attic insulation shield. It must be under joists between floors that are not insulated. Refer to Figure 8.4.
- Secure with three fasteners on each side.

**WARNING! Risk of Fire! DO NOT pack insulation around the vent. Insulation must be kept back from the pipe to prevent overheating.**

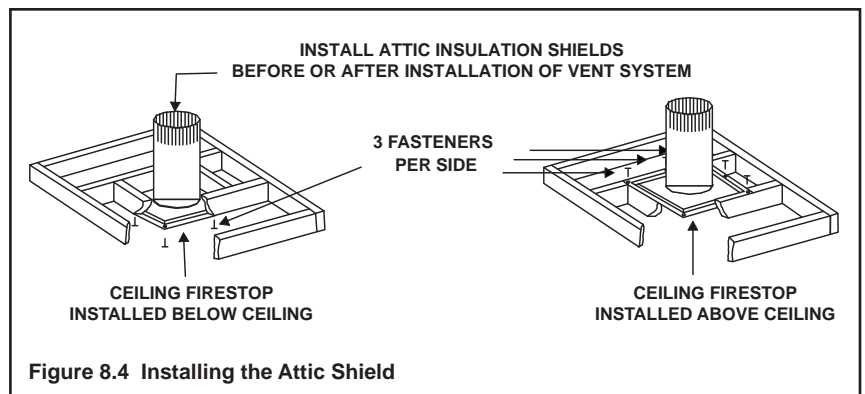
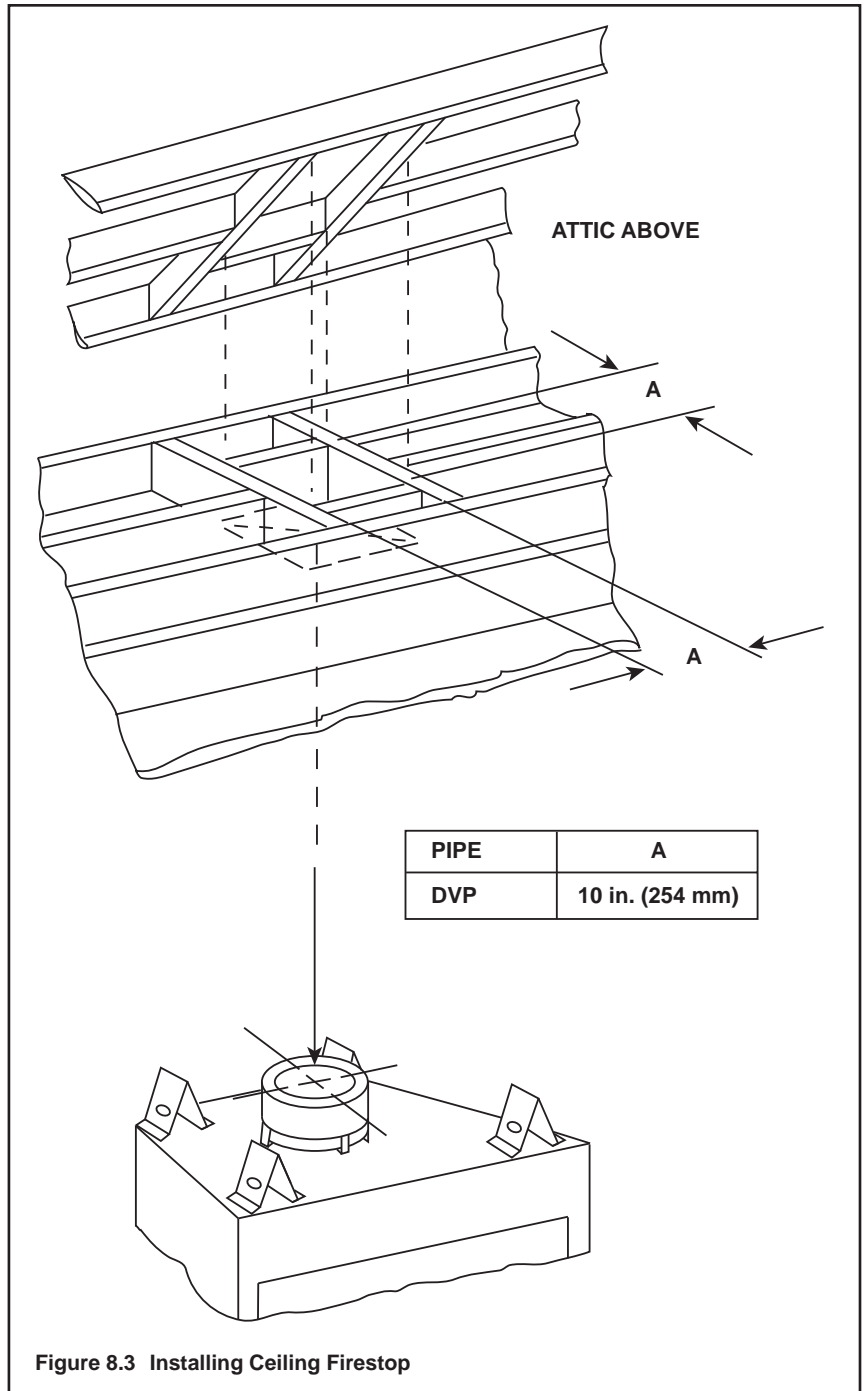

## D. Install Attic Insulation Shield

**WARNING! Fire Risk. DO NOT** allow loose materials or insulation to touch vent. Hearth & Home Technologies Inc. requires the use of an attic shield.

The National Fuel Gas Code ANSI Z223.1 and NFPA 54 requires an attic shield constructed of 26 gauge minimum metal that extends at least 2 in. (51 mm) above insulation.

Attic shields must meet specified clearance and be secured in place.

### Flat Ceiling Installation

- Remove one shield from box.

**NOTICE:** Cut previously installed batt insulation to make room for the attic insulation shield.

- Wrap shield around pipe if pipe is already installed in area to be insulated.
- Match the three holes in each side and fasten with three screws to form a tube.
- Bend three tabs on the bottom of the shield outward to allow attachment to the ceiling firestop.
- Bend the remaining bottom tabs inward 90° to maintain the air space between the pipe and the shield. Set the shield on the ceiling firestop and attach to the firestop.
- Bend all tabs inward 90° around the top of the shield. These tabs must be used to prevent blown insulation from getting between the shield and vent pipe, and to maintain air space clearance.

### Vaulted Ceiling Installation

- Remove one shield from box.

**NOTICE:** Cut previously installed batt insulation to make room for the attic insulation shield.

- Cut the attic insulation shield (if application is for vaulted ceiling) to fit your ceiling pitch. Snip cut edge to recreate 1 in. bend tabs all the way around the bottom.
- Wrap shield around pipe if pipe is already installed in area to be insulated.
- Match the three holes in each side and fasten with three screws to form a tube.
- Bend three tabs on the bottom of the shield outward to allow attachment to the ceiling firestop.
- Bend the remaining bottom tabs inward 90° to maintain the air space between the pipe and the shield. Set the shield on the ceiling firestop and attach to the firestop.
- Bend all tabs inward 90° around the top of the shield. These tabs must be used to prevent blown insulation from getting between the shield and vent pipe, and to maintain air space clearance.

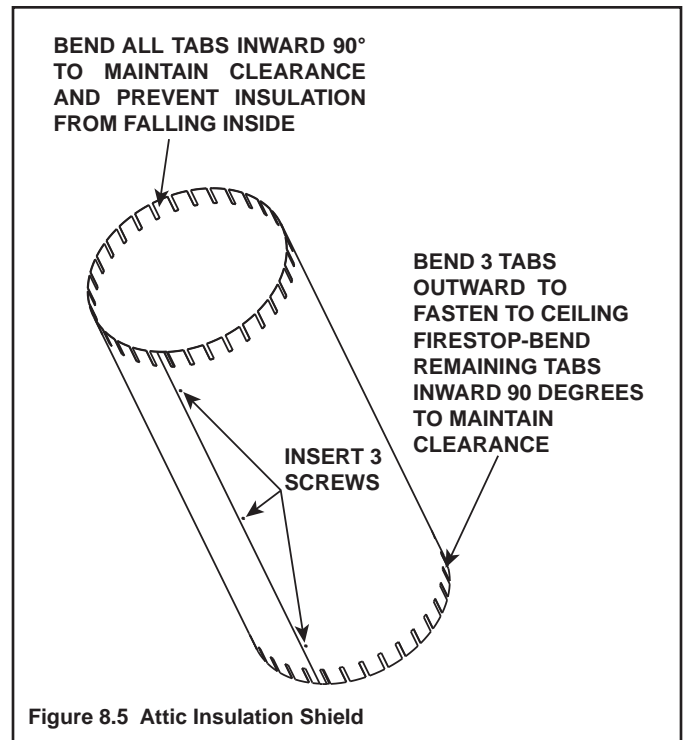

## E. Installing the Optional Heat-Zone® Gas Kit

- Locate the Heat-Zone® ports on the left and right sides of the appliance. See Figure 8.6. Remove the knockouts from the appliance with a tin snips.
- Center the duct collar around the exposed hole and attach it to the appliance with 3 screws. Note: Do this BEFORE final positioning of the appliance.
- Determine the location for the air register/fan housing assembly.

Reference the Heat-Zone® Gas Kit instructions for the remaining installation steps.

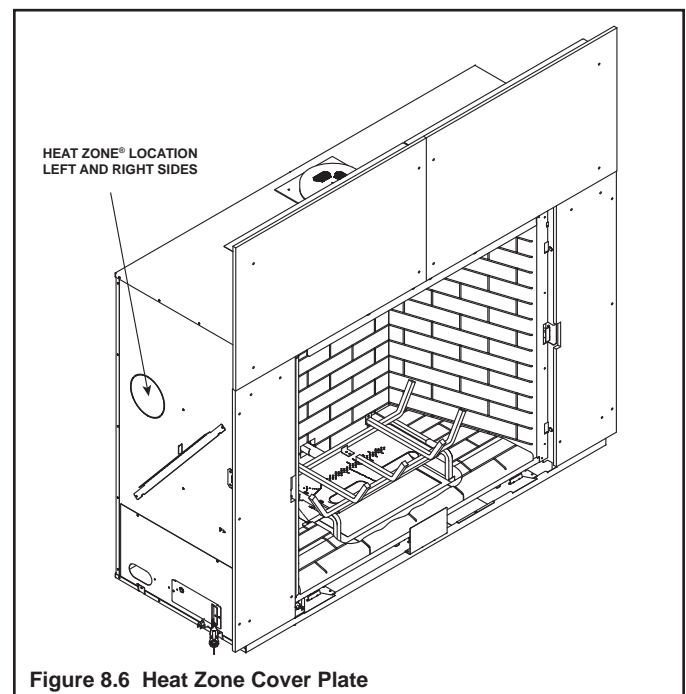

# 9 Appliance Preparation

## A. Vent Preparation

**CAUTION! Risk of Cuts, Abrasions or Flying Debris.** Wear protective gloves and safety glasses during installation. Sheet metal edges are sharp.

**NOTICE:** This appliance is top vented ONLY.

1. Remove shrink wrap from appliance. Figure 9.1 shows the shipping location of the seal cap and heat shields (Section 9), splatter guard and finishing templates (Section 13), and the logs and Teco-Sil (Section 14).
2. Remove seal cap from top of appliance by removing one screw, which is included, to prevent construction material from getting into appliance. Remove seal cap when pipe installation phase begins. See Figure 9.2.
3. Ensure gasket seal is in place prior to installing vent pipe sections. Gasket is installed at the factory.



Figure 9.2 Seal Cap and Gasket Location



Figure 9.1 Shipping Location of Components

## B. Securing and Leveling the Appliance

**WARNING! Risk of Fire!** Prevent contact with:

- Sagging or loose insulation
- Insulation backing or plastic
- Framing and other combustible materials

Block openings into the chase to prevent entry of blown-in insulation. Make sure insulation and other materials are secured.

**DO NOT** notch the framing around the appliance standoffs.

Failure to maintain air space clearance may cause overheating and fire.

Nailing tabs are provided on the appliance and on the heat shields to secure the appliance to the framing members. See Figure 9.3 and Figure 9.5 for location of nailing tabs in shipping position.

- Bend out side nailing tabs 90 degrees. See Figure 9.4.
- Place the appliance into position.
- Keep side nailing tabs flush with the framing.
- Level the appliance from side to side and front to back.
- Shim the appliance as necessary. It is acceptable to use wood shims underneath the appliance.
- Position and install heat shields by securing two screws in each heat shield. See Figure 9.1 for shipping location of heat shields. The heat shield screws can be found pre-installed on the top of the appliance.
- Bend the top header heat shields upward to position them vertically and bend out the two nailing tabs on the top of each header heat shield. Secure to framing. See Figure 9.5.
- Secure the appliance to the framing by using nails or screws through the nailing tabs.
- Secure the appliance to the floor by inserting two screws through the pilot holes at the bottom of the appliance.

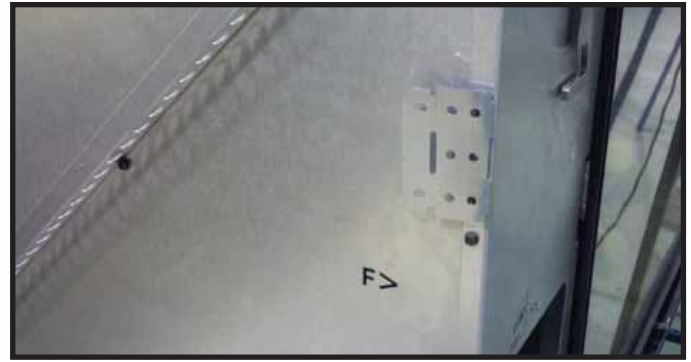

Figure 9.3 Side Nailing Tab in Shipping Position

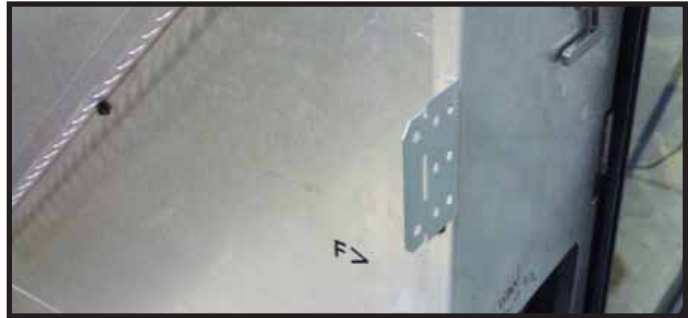

Figure 9.4 Nailing Tab Bent Out for Installation

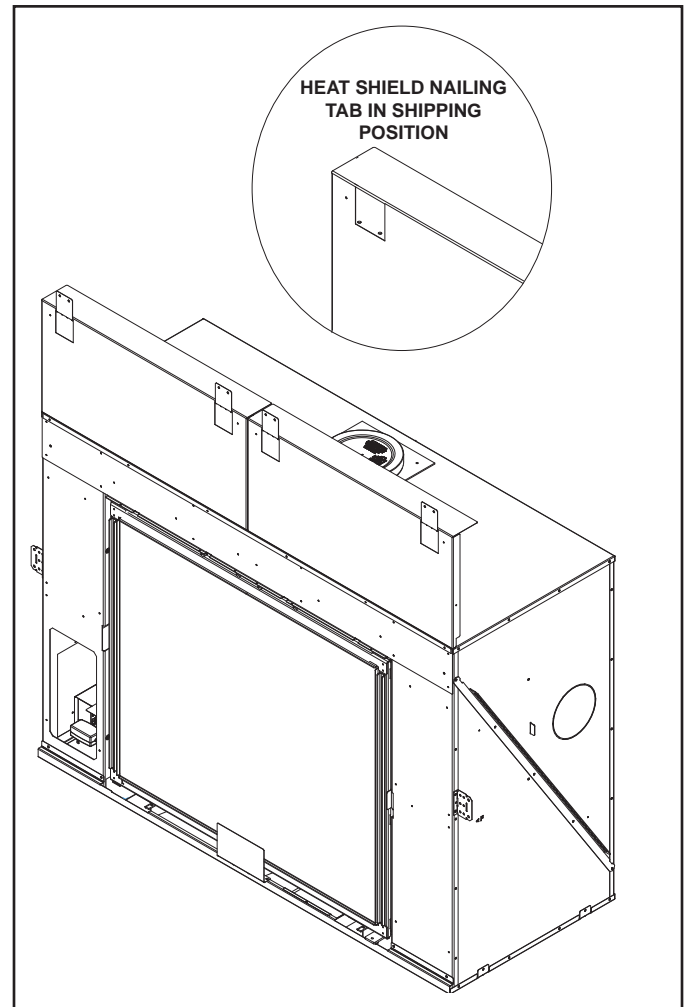

Figure 9.5. Heat Shields and Nailing Tabs in Installation Position

## C. Installing Non-combustible Facing Material

### **WARNING! Risk of Fire!**

- Follow these instructions exactly.
- Facing materials must be installed properly to prevent fire.
- No materials may be substituted without authorization by *Hearth & Home Technologies*.
- The finishing templates are shipped fastened to the top surround. Remove finishing templates prior to installing non-combustible board.
- Remove non-combustible facing pieces from back of appliance. See Figure 9.6.
- Install non-combustible facing material to the appliance using the screws supplied in the manual bag assembly.
- Center and attach two top boards to the framing members. See Figure 9.7.
- Attach left and right side pieces to framing members.
- Use fasteners from fastener packet (in manual bag) for screws that secure to the fireplace. See Figure 9.7.
- Use regular sheetrock screws or nails to secure the perimeter of the non-combustible facing materials to the wood framing. See Figure 9.7.
- Use a wet or dry towel or soft brush to remove dust or dirt from facing material.
- See Section 13 for finishing materials guidelines.



Figure 9.6 Shipping Location of Non-Combustible Board

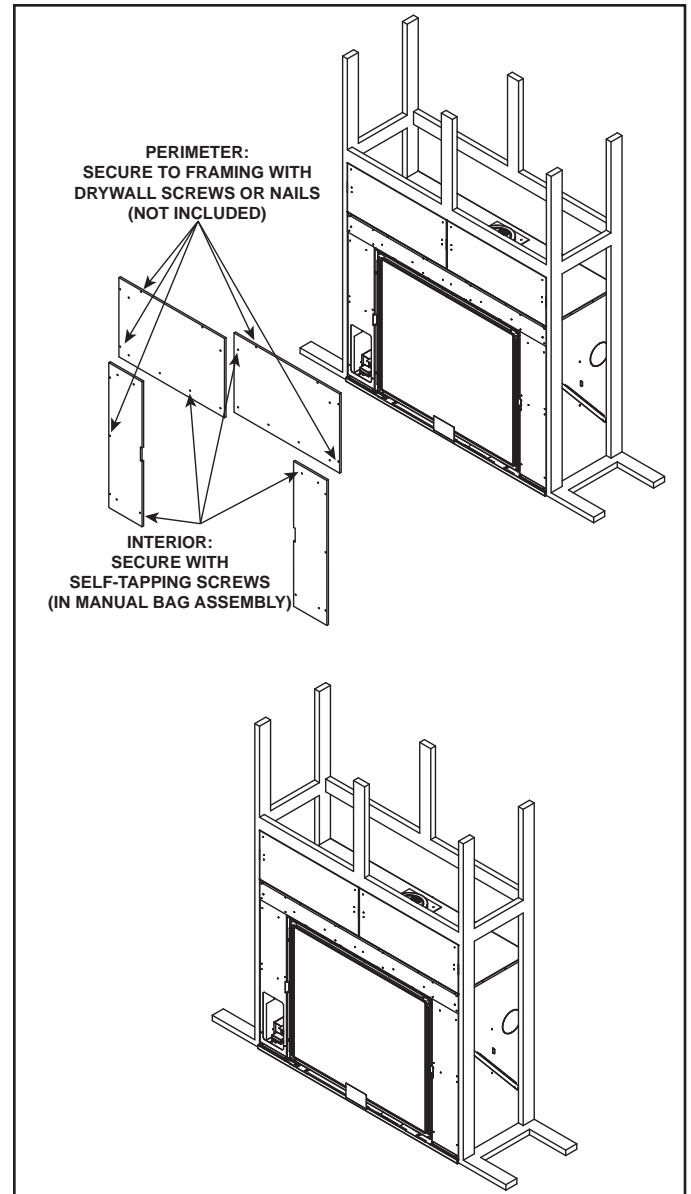

Figure 9.7 Installing Non-Combustible Facing Material

# 10 Installing Vent Pipe (DVP Pipe)

## A. Assemble Vent Sections

### Attach Vent to the Firebox Assembly

**Note:** The end of the pipe sections with the lanced tabs will face toward the appliance.

Attach the first pipe section to the starting collar:

- Lanced pipe end of the starting collar.
- Inner pipe over inner collar.
- Push the pipe section until all lanced tabs snap in place.
- Lightly tug on pipe to confirm it has locked.

### Commercial, Multi-family (Multi-level exceeding two stories), or High-Rise Applications

All outer pipe joints must be sealed with high temperature silicone (300°F minimum continuous exposure rating), including the slip section that connects directly to the horizontal termination cap.

- Apply a bead of silicone sealant (300°F minimum continuous exposure rating) inside the female outer pipe joint prior to joining sections. See Figure 10.1.
- Only outer pipes need to be sealed. All unit collar, pipe, slip section, elbow and cap outer flues shall be sealed in this manner, unless otherwise stated.

**WARNING! Risk of Fire or Explosion! DO NOT break silicone seals on slip sections. Use care when removing termination cap from slip pipe. If slip section seals are broken during removal of the termination cap, vent may leak.**

### Assemble Pipe Sections

Per Figure 10.2:

- Start the inner pipe on the lanced end of section A into the flared end of section B.
- Start the outer pipe of section A over the outer pipe of section B.
- Once both vents sections are started, push firmly until all lanced tabs lock into place.
- Lightly tug on the pipe to confirm the tabs have locked.

It is acceptable to use screws no longer than 1/2 in. (13 mm) to hold outer pipe sections together. If predrilling holes, **DO NOT** penetrate inner pipe.

For 90° and 45° elbows that are changing the vent direction from horizontal to vertical, one screw minimum should be put in the outer flue at the horizontal elbow joint to prevent the elbow from rotating. Use screws no longer than 1/2 in. (13 mm). If predrilling screw holes, **DO NOT** penetrate inner pipe.



Figure 10.1 High Temperature Silicone Sealant

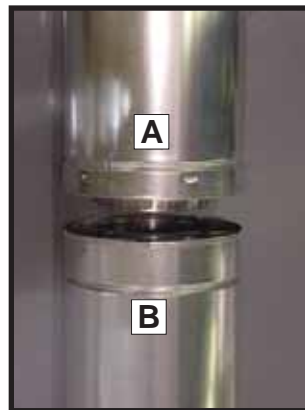

Figure 10.2



Figure 10.3

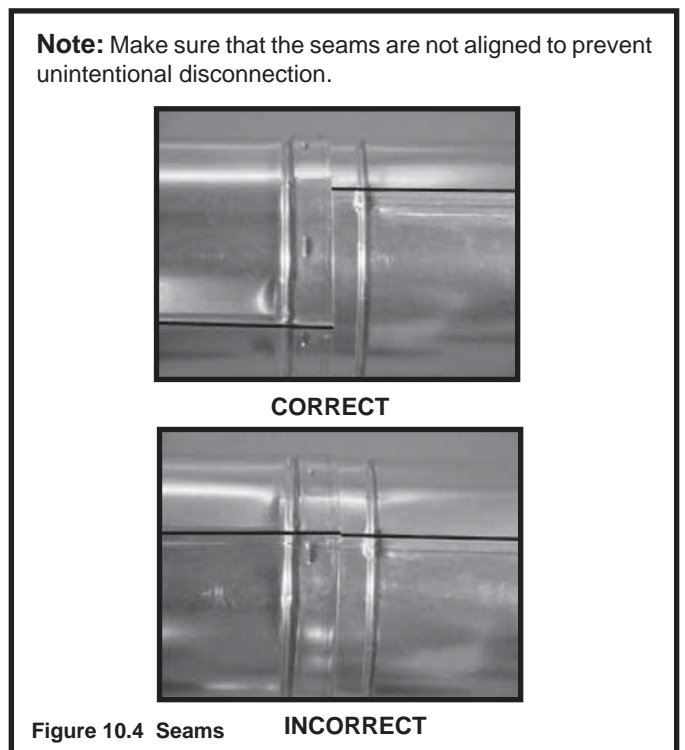

Figure 10.4 Seams



## B. Secure the Vent Sections

- Vertical runs of DVP pipe must be supported every 8 ft. (2.44 m) after the 25 ft. (7.62 m) maximum unsupported rise.
- Horizontal sections must be supported every 5 feet (1.52 m).
- Vent supports or plumbers strap (spaced 120° apart) may be used to support vent sections. See Figures 10.5 and 10.6.
- Wall shield firestops may be used to provide horizontal support to vent sections.

**WARNING! Risk of Fire, Explosion or Asphyxiation!** Improper support may allow vent to sag and separate. Use vent run supports and connect vent sections per installation instructions. **DO NOT** allow vent to sag below connection point to appliance.

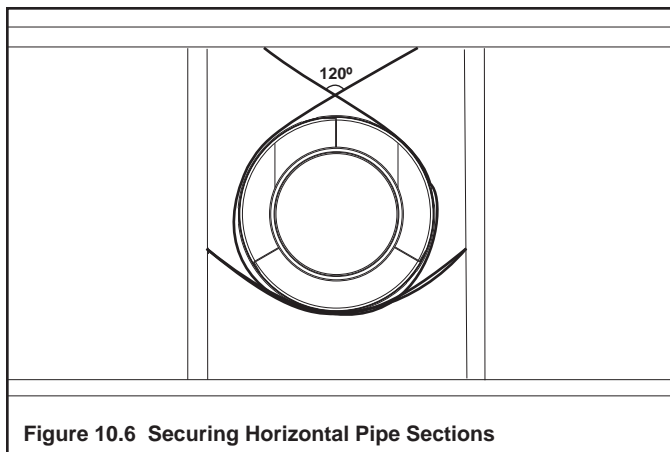
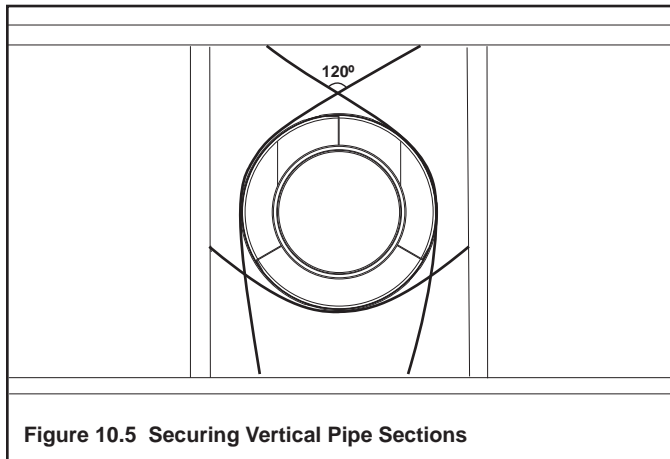

## C. Disassemble Vent Sections

- Rotate either section (see Figure 10.7) so the seams on both pipe sections are aligned as shown in Figure 10.8.
- Pull carefully to separate the pieces of pipe.

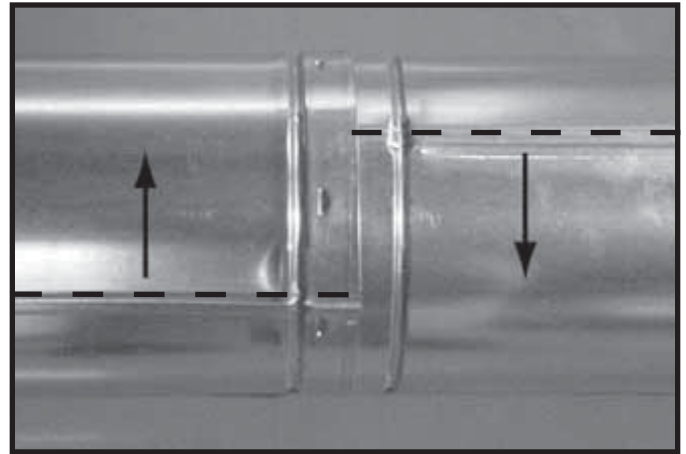

Figure 10.7 Rotate Seams for Disassembly

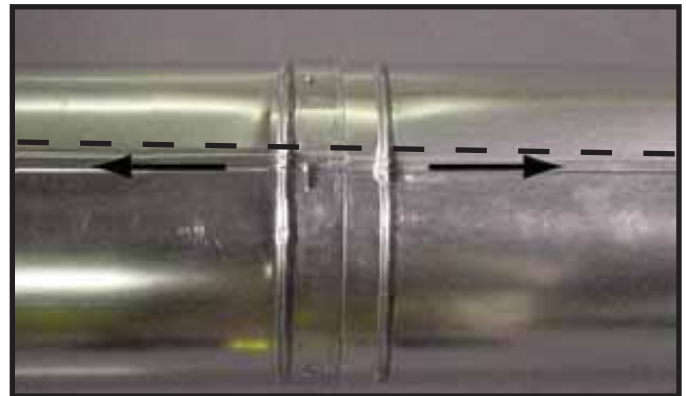
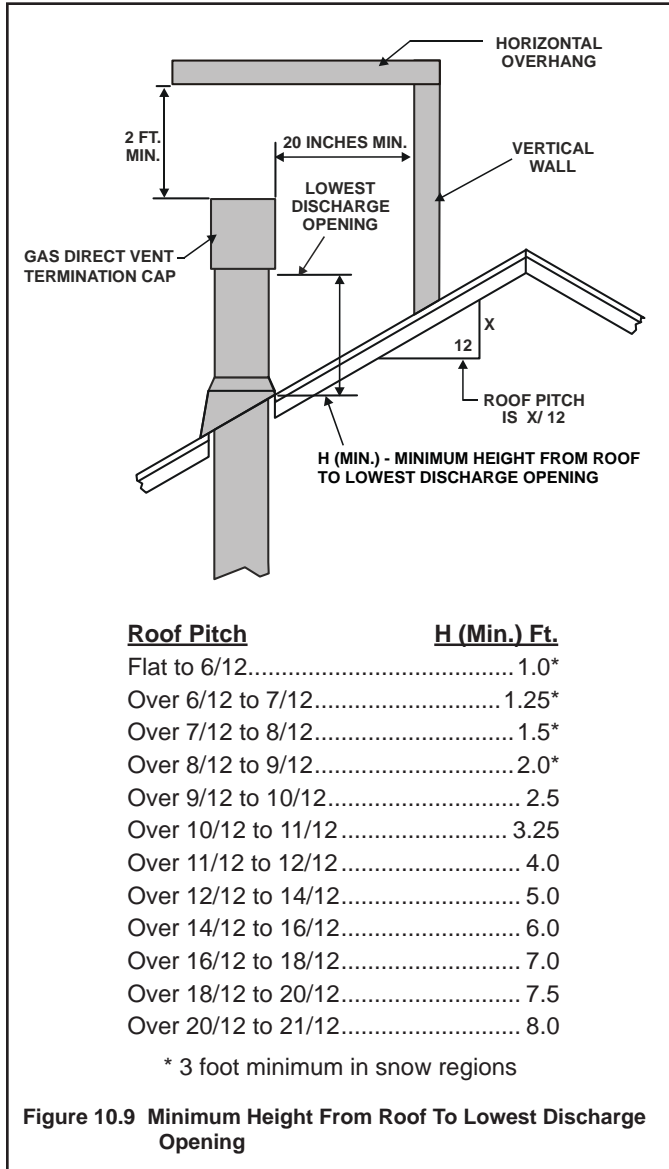

Figure 10.8 Align and Disassemble Vent Sections

## D. Install Metal Roof Flashing

- See minimum vent heights for various pitched roofs (Figure 10.9) to determine the length of pipe to extend through the roof.
- Slide the roof flashing over the pipe sections extending through the roof as shown in Figure 10.10.



**NOTICE:** Failure to properly caulk the roof flashing and pipe seams may permit entry of water.

- Caulk the gap between the roof flashing and the outside diameter of the pipe.
- Caulk the perimeter of the flashing where it contacts the roof surface. See Figure 10.10.
- Caulk the overlap seam of any exposed pipe sections that are located above the roof line.

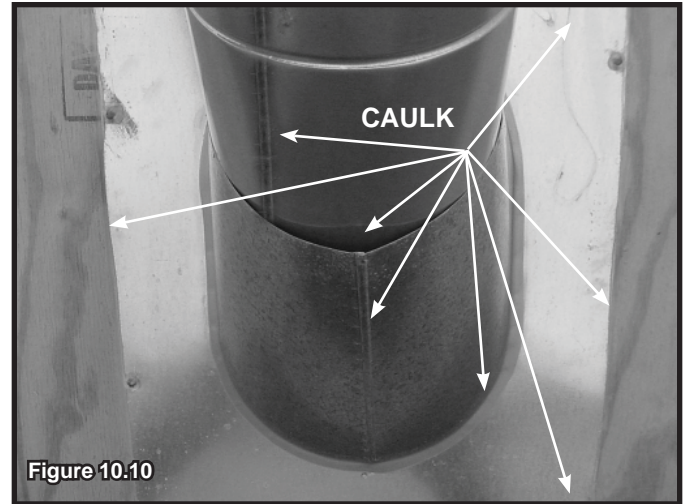

## E. Assemble and Install Storm Collar

**CAUTION! Risk of Cuts, Abrasions or Flying Debris.** Wear protective gloves and safety glasses during installation. Sheet metal edges are sharp.

- Connect both halves of the storm collar with two screws (see Figure 10.11).
- Wrap the storm collar around the exposed pipe section closest to the roof and align brackets. Insert a bolt (provided) through the brackets and tighten the nut to complete the storm collar assembly. Make sure the collar is tight against the pipe section.
- Slide the assembled storm collar down the pipe section until it rests on the roof flashing (see Figure 10.12).
- Caulk around the top of the storm collar (see Figure 10.13).

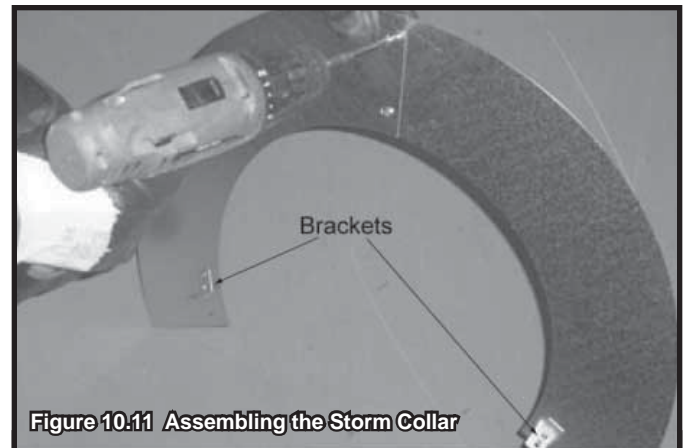

## F. Install Vertical Termination Cap

- Attach the vertical termination cap by sliding the inner collar of the cap into the inner flue of the pipe section while placing the outer collar of the cap over the outer flue of the pipe section.
- Secure the cap by driving three self-tapping screws (supplied) through the pilot holes in the outer collar of the cap into the outer flue of the pipe (see Figure 10.13).



Figure 10.13

## G. Heat Shield Requirements for Horizontal Termination

**WARNING! Risk of Fire!** To prevent overheating and fire, heat shields must extend through the entire wall thickness.

- **DO NOT** remove the heat shields attached to the wall shield firestop and the horizontal termination cap shown in Figure 10.14.
- Heat shields must overlap 1-1/2 in. (38 mm) minimum.

There are two sections of the heat shield. One section is factory-attached to the wall shield firestop. The other section is factory-attached to the cap. See Figure 10.14.

If the wall thickness does not allow the required 1-1/2 in. (38 mm) heat shield overlap when installed, an extended heat shield must be used.

- If the wall thickness is less than 4 in./102 mm (DVP), the heat shields on the cap and wall shield firestop must be trimmed. A minimum 1-1/2 in. (38 mm) overlap **MUST** be maintained.
- Use an extended heat shield if the finished wall thickness is greater than 7-1/4 in. (184 mm).

- The extended heat shield may need to be cut to length maintaining sufficient length for a 1-1/2 in. (38 mm) overlap between heat shields.
- Attach the extended heat shield to either of the existing heat shields using the screws supplied with the extended heat shield. Refer to vent components diagrams in the back of this manual.
- Rest the small leg on the extended heat shield on top of the pipe section to properly space it from the pipe section.

**Important Notice:** Heat shields may not be field constructed.

## H. Install Horizontal Termination Cap

**WARNING! Risk of Fire!** The telescoping flue section of the termination cap **MUST** be used when connecting vent.

- 1-1/2 (38 mm) minimum overlap of flue telescoping section is required.

Failure to maintain overlap may cause overheating and fire.

- Vent termination must not be recessed in the wall. Siding may be brought to the edge of the cap base.
- Flash and seal as appropriate for siding material at outside edges of cap.
- When installing a horizontal termination cap, follow the cap location guidelines as prescribed by current **ANSI Z223.1** and **CAN/CGA-B149** installation codes and refer to Section 6 of this manual.

**CAUTION! Risk of Burns!** Local codes may require installation of a cap shield to prevent anything or anyone from touching the hot cap.

**NOTICE:** For certain exposures which require superior resistance to wind-driven rain penetration, a flashing kit is available. When penetrating a brick wall, a brick extension kit is available for framing the brick.

**Note:** When using termination caps with factory-supplied heat shield attached, no additional wall shield firestop is required on the exterior side of a combustible wall.

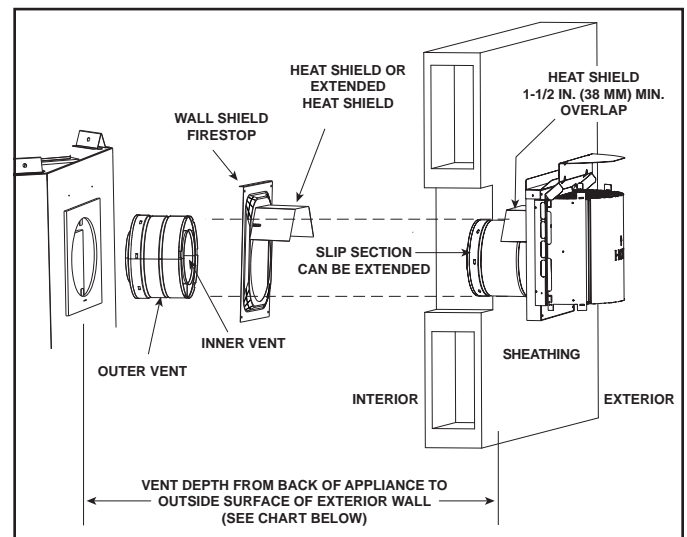

Figure 10.14 Venting through the wall

# 11 Gas Information

## A. Fuel Conversion

- Make sure the appliance is compatible with available gas types.
- Conversions must be made by a qualified service technician using Hearth & Home Technologies specified and approved parts.

## B. Gas Pressure

- Optimum appliance performance requires proper input pressures.
- Gas line sizing requirements will be determined in ANSI Z223.1 National Fuel Gas Code in the USA and CAN/CGA B149 in Canada.
- Pressure requirements are:

Gas Pressure	Natural Gas	Propane
Minimum inlet pressure	5.0 in. w.c.	11.0 in. w.c.
Maximum inlet pressure	10.0 in. w.c.	13.0 in. w.c.
Manifold pressure	3.5 in. w.c.	10.0 in. w.c.

**WARNING! Risk of Fire or Explosion!** High pressure will damage valve. Low pressure may cause explosion.

- Verify inlet pressures. Verify minimum pressures when other household gas appliances are operating.
- Install regulator upstream of valve if line pressure is greater than 1/2 psig.

**⚠ WARNING**



Fire Risk.  
Explosion Hazard.  
High pressure will damage valve.

- Disconnect gas supply piping **BEFORE** pressure testing gas line at test pressures above 1/2 psig.
- Close the manual shutoff valve **BEFORE** pressure testing gas line at test pressures equal to or less than 1/2 psig.

**Note:** Have the gas supply line installed in accordance with local codes, if any. If not, follow ANSI 223.1. Installation should be done by a qualified installer approved and/or licensed as required by the locality. (In the Commonwealth of Massachusetts installation must be performed by a licensed plumber or gas fitter).

**Note:** A listed (and Commonwealth of Massachusetts approved) 1/2 in. (13 mm) T-handle manual shut-off valve and flexible gas connector are connected to the 1/2 in. (13 mm) control valve inlet.

- **If substituting for these components, please consult local codes for compliance.**

## C. Gas Connection

- Refer to Reference Section 16 for location of gas line access in appliance.
- Gas line may be run through knockout(s) provided.
- The gap between supply piping and gas access hole may be caulked with caulk with a minimum of 300°F continuous exposure rating or stuffed with non-combustible, unfaced insulation to prevent cold air infiltration.
- Ensure that gas line does not come in contact with outer wrap of the appliance. Follow local codes.
- Pipe incoming gas line into valve compartment.
- Connect incoming gas line to the 1/2 in. (13 mm) connection on manual shutoff valve.

**WARNING! Risk of Fire or Explosion!** Support control when attaching pipe to prevent bending gas line.

- A small amount of air will be in the gas supply lines.

**WARNING! Risk of Fire or Explosion!** Gas build-up during line purge could ignite.

- Purge should be performed by qualified service technician.
- Ensure adequate ventilation.
- Ensure there are no ignition sources such as sparks or open flames.

Light the appliance. It will take a short time for air to purge from lines. When purging is complete the appliance will light and operate normally.

**WARNING! Risk of Fire, Explosion or Asphyxiation!** Check all fittings and connections with a non-corrosive commercially available leak-check solution. **DO NOT** use open flame. Fittings and connections could have loosened during shipping and handling.

**WARNING! Risk of Fire! DO NOT** change valve settings. This valve has been preset at the factory.

## D. High Altitude Installations

**NOTICE:** If the heating value of the gas has been reduced, these rules do not apply. Check with your local gas utility or authorities having jurisdiction.

When installing above 2000 feet elevation:

- In the USA: Reduce burner orifice 4% for each 1000 feet above 2000 feet.
- In CANADA: Reduce burner orifice 10% for elevations between 2000 feet and 4500 feet. Above 4500 feet, consult local gas utility.

# 12 Electrical Information

## A. Wiring Requirements

**NOTICE:** This appliance must be electrically wired and grounded in accordance with local codes or, in the absence of local codes, with **National Electric Code ANSI/NFPA 70-latest edition** or the **Canadian Electric Code CSA C22.1**.

- Wire the appliance junction box to 110-120 VAC. This is required for use of optional accessories (standing pilot ignition) or proper operation of the appliance (IntelliFire Plus™ ignition).
- A 110-120 VAC circuit for this product must be protected with ground-fault circuit-interrupter protection, in compliance with the applicable electrical codes, when it is installed in locations such as in bathrooms or near sinks.
- Low voltage and 110 VAC voltage cannot be shared within the same wall box.

**WARNING! Risk of Shock or Explosion! DO NOT wire 110V to the valve or to the appliance wall switch. Incorrect wiring will damage controls.**

## B. IntelliFire Plus™ Ignition System Wiring

- Wire the appliance junction box to 110-120 VAC for proper operation of the appliance.

**WARNING! Risk of Shock or Explosion! DO NOT wire IPI controlled appliance junction box to a switched circuit. Incorrect wiring will override IPI safety lockout.**

- Refer to Figure 12.1, IPI Wiring Diagram.
- This appliance is equipped with an IntelliFire Plus™ control valve which operates on a 6 volt/1.5 AMP system.
- Plug the 6 volt transformer plug into the appliance junction box to supply power to the unit OR install 4 AA batteries (not included) into the battery pack before use.

## C. Optional Accessories Requirements

- This appliance may be used with a wall switch, wall mounted thermostat and/or a remote control.

Wiring for optional Hearth & Home Technologies approved accessories should be done now to avoid reconstruction. Follow instructions that come with those accessories.

- Hearth & Home Technologies recommends that IntelliFire Plus™ wireless controls be used for their features and functionality with the IntelliFire Plus™ ignition system.

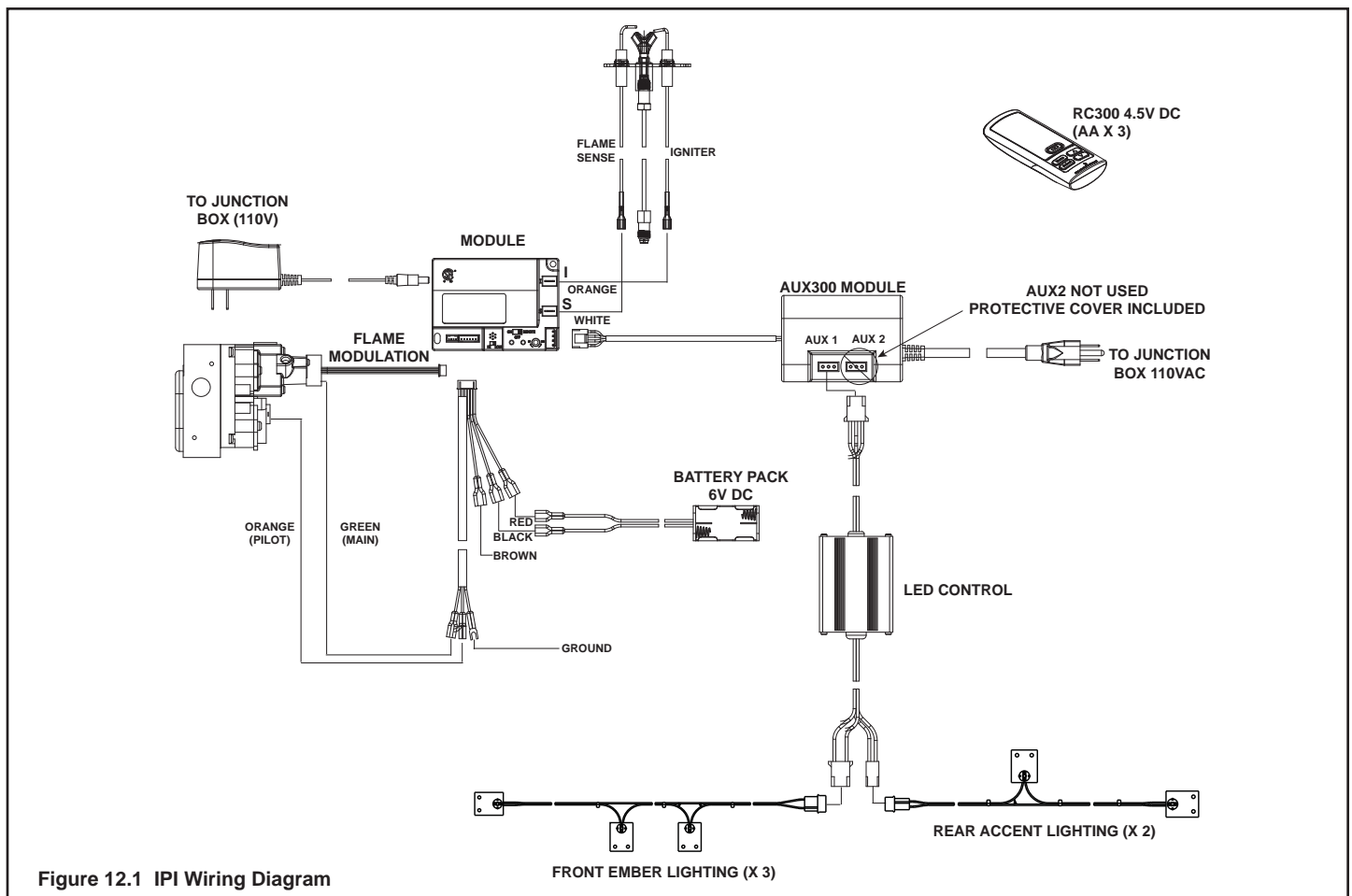

Figure 12.1 IPI Wiring Diagram

## D. Electrical Service and Repair

**WARNING! Risk of Shock!** Label all wires prior to disconnection when servicing controls. Wiring errors can cause improper and dangerous operation. Verify proper operation after servicing.

**WARNING! Risk of Shock!** Replace damaged wire with type 105° C rated wire. Wire must have high temperature insulation.

## E. Junction Box Installation

If the box is being wired from the **INSIDE** of the appliance:

- The junction box is accessible through the front left column if finishing materials have not been installed. The junction box is also accessible through the firebox access panel. See Figure 12.2.
- Remove the screw attaching the junction box/receptacle to the outer shell, rotate the junction box inward to disengage it from the outer shell. See Figure 12.3.
- Pull the electrical wires from outside the appliance through the opening into the valve compartment and secure wires with a Romex connector. See Figure 12.3
- Make all necessary wire connections to the junction box/receptacle and reattach the junction box/receptacle to the outer shell.

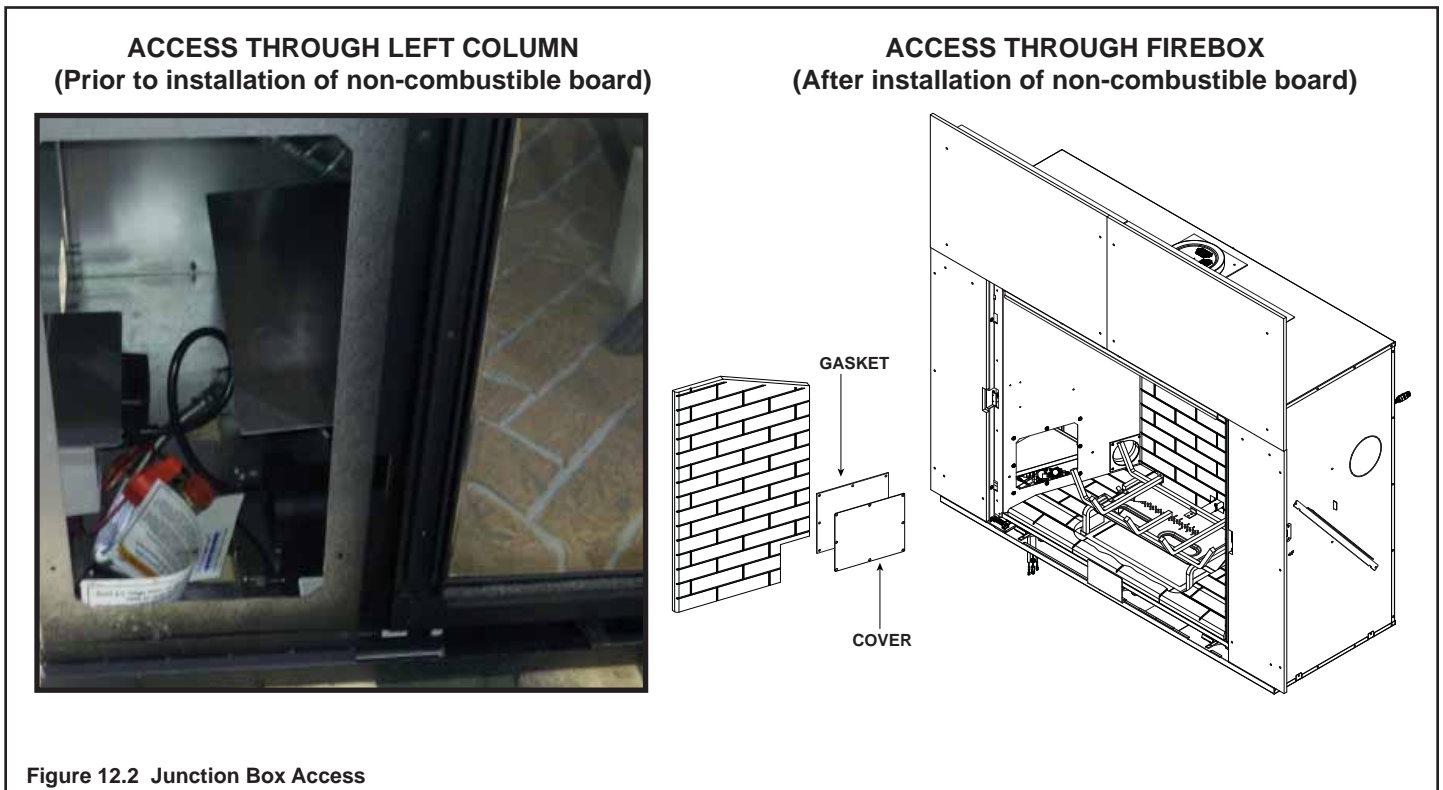
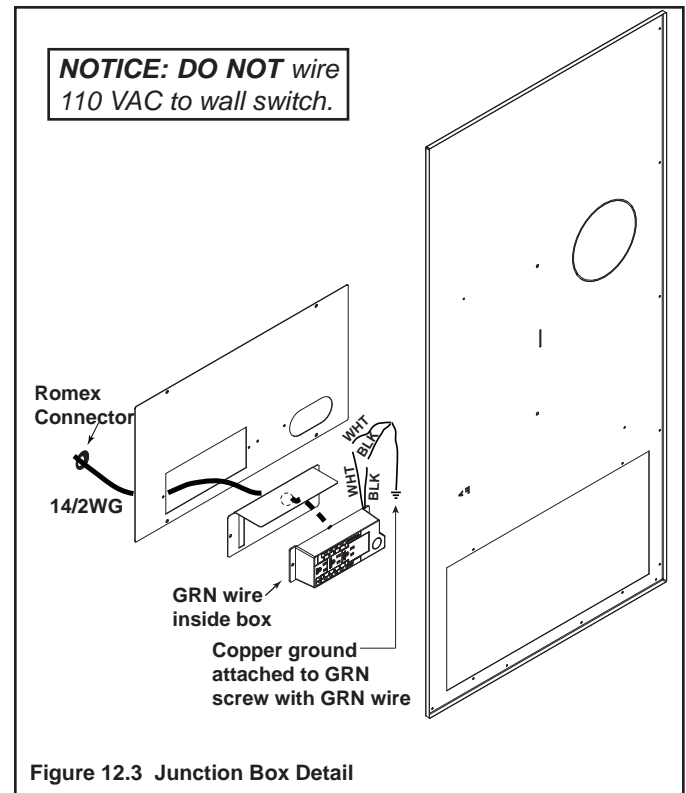

# 13 Finishing

## A. Finishing Templates

Two side finishing templates and one top finishing template are supplied with the appliance. They are fastened to the top surround.

**INSIDE FIT Method:** The finishing template pieces are required for installations that require more than one inch thick finishing materials to be installed over the face of the factory-supplied 1/2 inch non-combustible board. Refer to section 13.E for more information.

**OVERLAP Method:** The supplied templates are not required for finishing materials less than one inch thick. The required decorative front will overlap finish materials less than one inch thick. Refer to section 13.E for more information.

**Note:** For Arch Door applications with finish material greater than one inch thick, an Arch Template Kit is available. Contact your dealer to order the arch template kit.

### Template installation instruction

1. Determine if the required door options is a inoperable (fixed style) or operable (cabinet style). Doors denoted with an FS are inoperable. Doors denoted with a CS are operable. Refer to Section 13.E for door information.
2. Bend the left and right side templates for the appropriate door type using Figure 13.2 as a reference.
3. Locate the four threaded inserts on the inside edge of the fireplace and secure the side templates with the Phillips screws provided. See Figure 13.3.
4. Bend the top template as shown in Figure 13.1 and secure with the two screws provided. The bend will have two opposing 90 degree bends, similar to the bends on the side templates.
5. Remove all template components once finishing materials are secured.

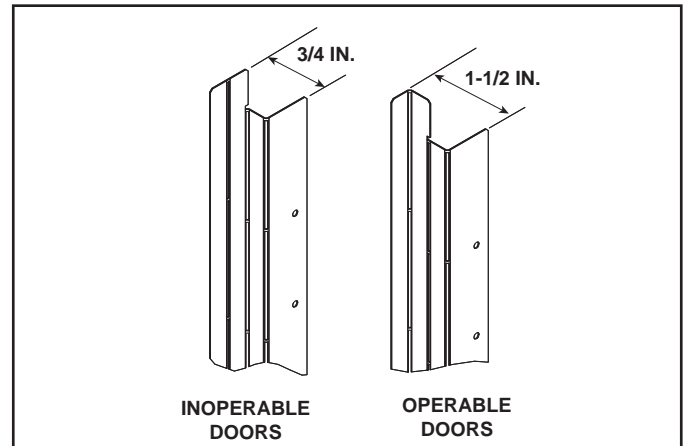

Figure 13.2 Left and Right Side Finishing Template Bends

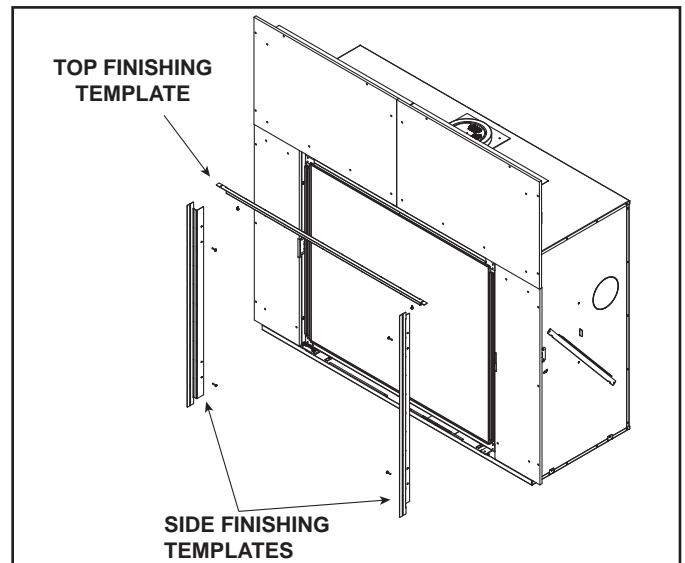

Figure 13.3 Top and Side Finishing Template Locations

**Note:** A thin layer of mortar may be applied over the visible non-combustible board between finishing material and the fireplace opening.

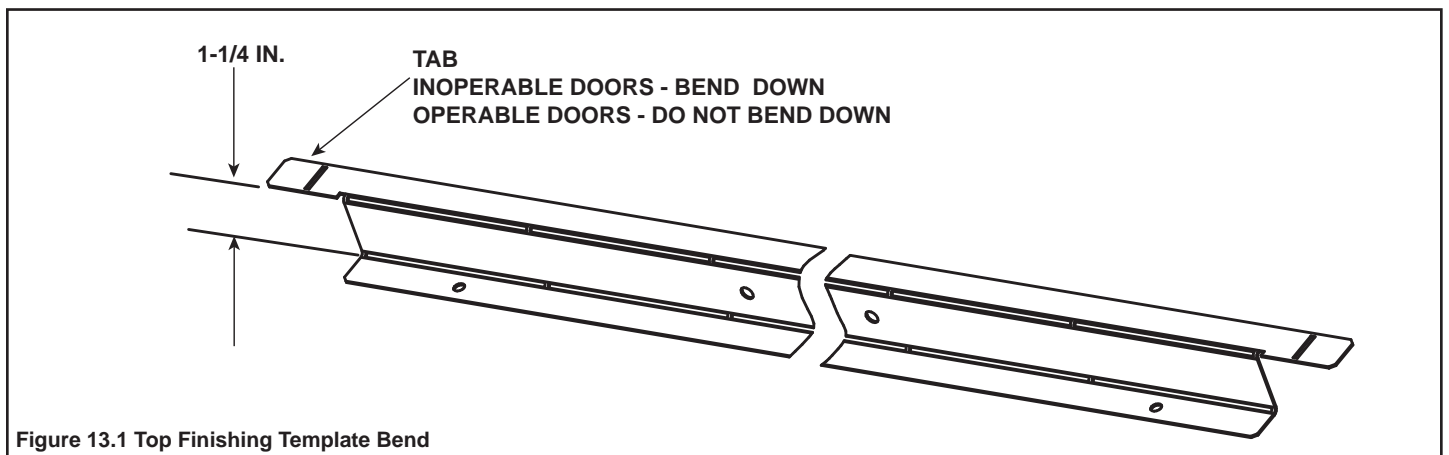

Figure 13.1 Top Finishing Template Bend



Figure 13.4 Finishing Templates Bends - Inoperable (Fixed) Doors



Figure 13.5 Finishing Template Bend - Operable Doors

## B. Splatter Guard

The splatter guard is a piece of corrugated material used to protect the appliance during the installation process before finishing work on the whole hearth is complete. Splatter guards may be factory installed or accompany the door of the appliance, depending on the model. Splatter guards must be removed before appliance is fired.

**WARNING! Risk of Fire!** Close the ball valve before installing the splatter guard to prevent accidental lighting. Remove the splatter guard before lighting the appliance.

1. Fold top flap along scored lines.
2. Slide side tabs into slots by sides of glass.



Figure 13.6. Splatter Guard Installation



### C. Mantel and Wall Projections

**WARNING! Risk of Fire!** Comply with all minimum clearances as specified. Framing or finishing material closer than the minimums listed must be constructed entirely of non-combustible materials (i.e., steel studs, concrete board, etc).

When installing a mantel, provisions must be made in order to secure the mantel to the adjacent framing materials. For example, lintel brackets or lag bolts may be considered for this purpose.

#### Combustible Mantel Legs or Wall Projections

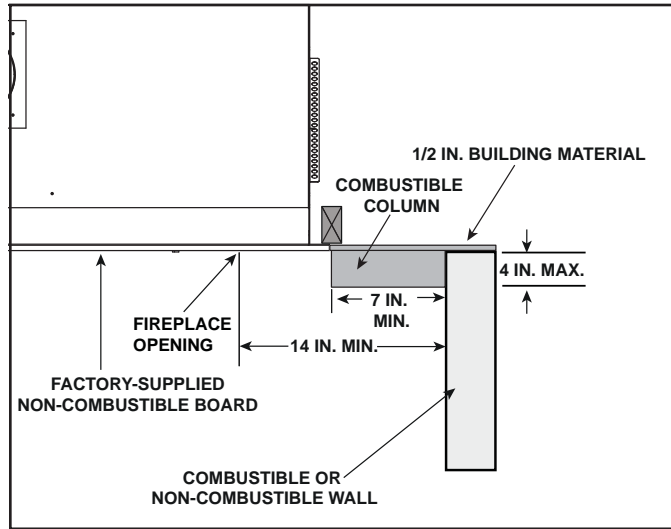

Figure 13.7 Combustible Mantel Leg and Wall Projections

#### Non-Combustible Mantel Legs or Wall Projections

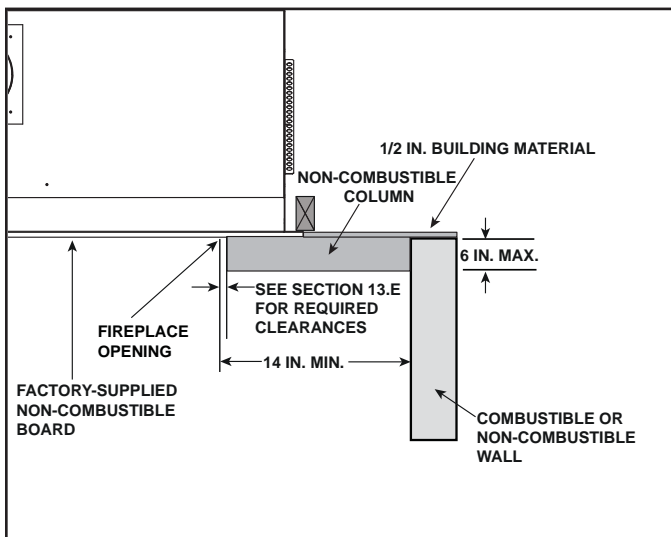

Figure 13.8 Non-Combustible Mantel Leg and Wall Projections

#### Non-Combustible Zone

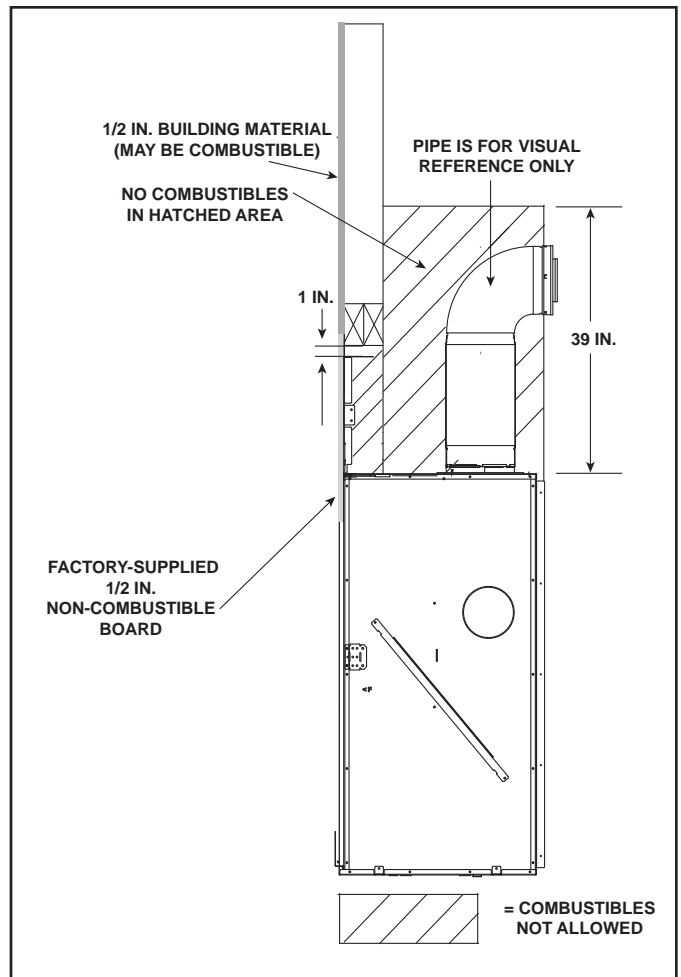

Figure 13.9 Non-Combustible Zone

### Combustible Mantel Projections

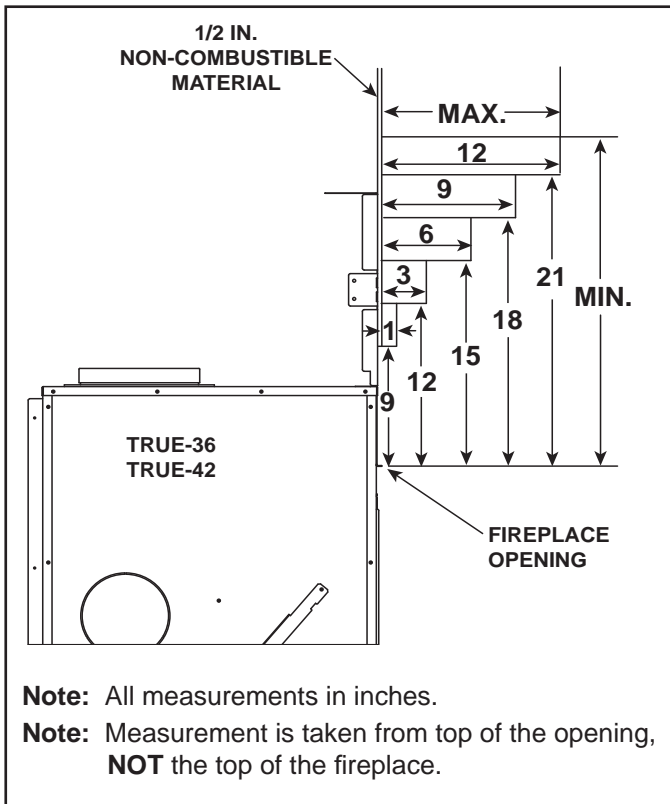

Figure 13.10 Combustible Mantel Allowance - TRUE-36, TRUE-42

### Non-Combustible Mantel Projections

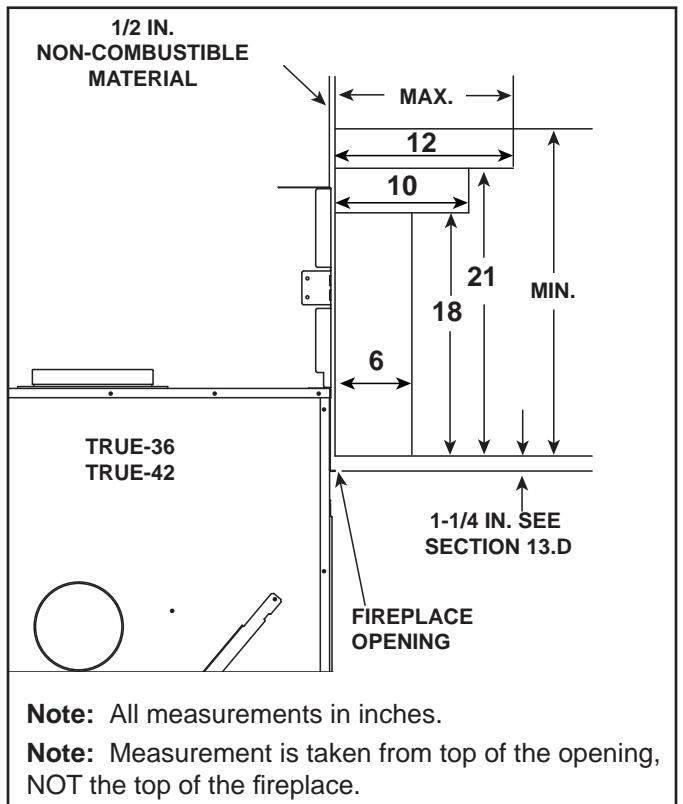

Figure 13.12 Non-Combustible Mantel Allowance - TRUE-36, TRUE-42

### Combustible Mantel Projections

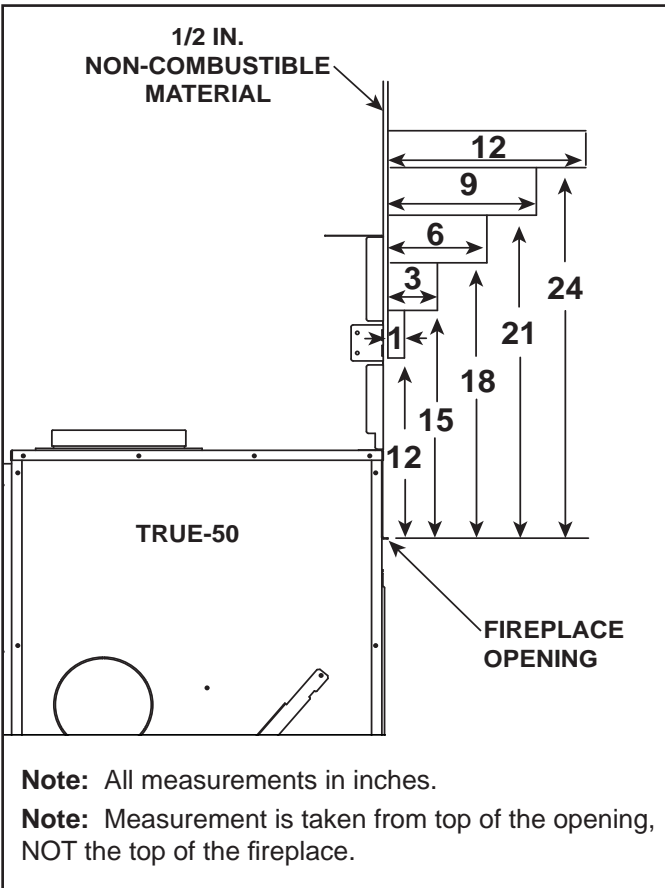

Figure 13.11 Combustible Mantel Allowance - TRUE-50

### Non-Combustible Mantel Projections

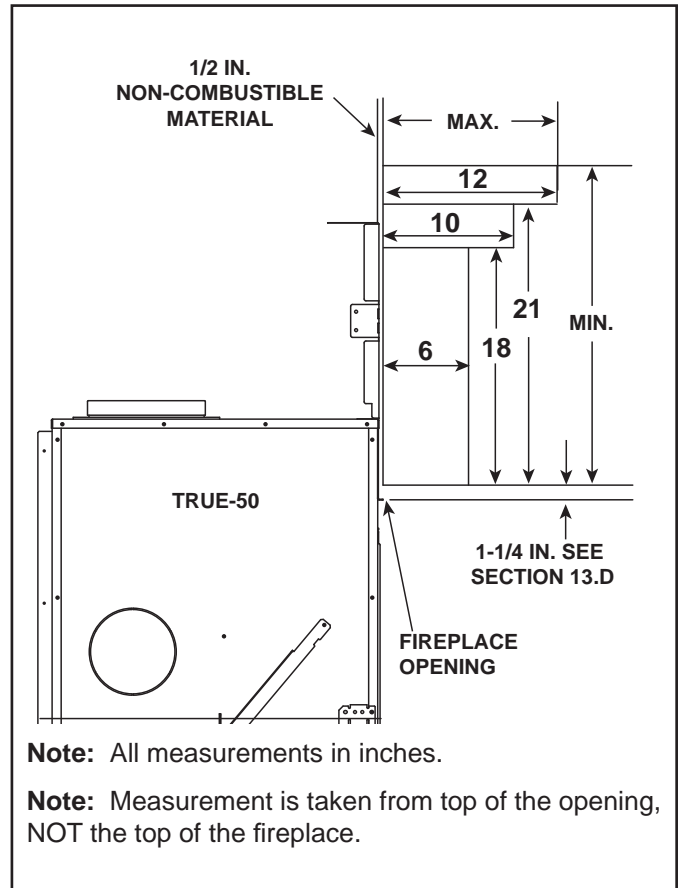

Figure 13.13 Non-Combustible Mantel Allowance - TRUE-50

## D. Facing Material

- Metal front faces may be covered with non-combustible materials only.
- Facing and/or finishing materials must not interfere with air flow through louvers, operation of louvers or doors, or access for service.
- Facing and/or finishing materials must never overhang into the glass opening.
- Observe all clearances when applying combustible materials.

**WARNING! Risk of Fire! DO NOT** apply combustible materials beyond the minimum clearances. Comply with all minimum clearances to combustibles as specified in this manual. Overlapping materials could ignite and will interfere with proper operation of doors and louvers.

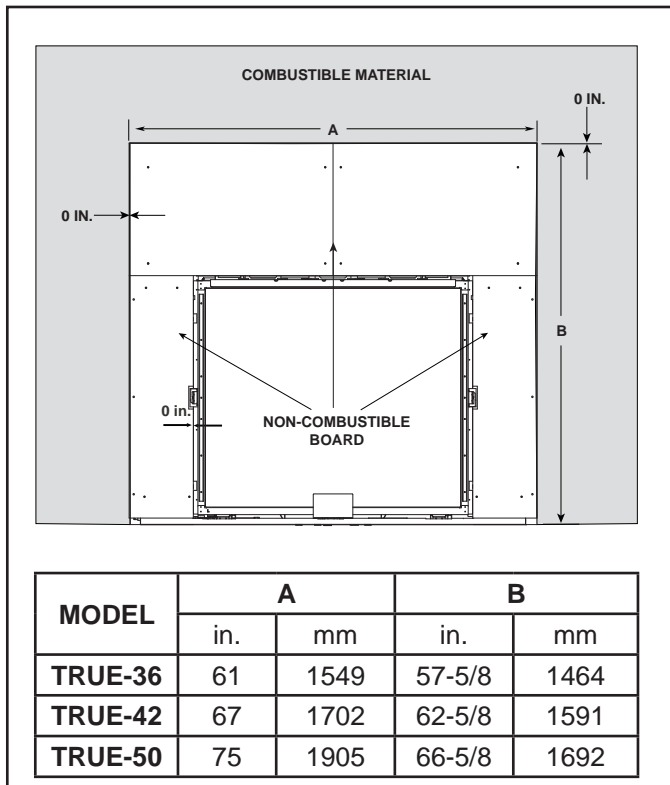

Figure 13.14 Non-combustible Facing Diagram

## E. Doors

A door (decorative front) is required for this appliance. Only doors certified for use with this appliance model may be used. Contact your dealer for a list of doors that may be used. Once you have determined what kind of door and finishing material is going to be used on the fire-place, you may use the table below which shows the door models and the finishing material thickness allowed. For an inside fit there is an available template to ensure that proper door clearances are maintained with finishing material with thickness greater than 1 inch.

Two styles of decorative doors are approved for use with this appliance: Operable cabinet-style doors and non-op-erable doors.

<b>OPERABLE DOORS</b>	
RECTANGULAR	
CS-36	
CS-42	
CS-50	
<b>INOPERABLE DOORS</b>	
RECTANGULAR	ARCHED
FS-36	FS-36A
FS-42	FS-42A
FS-50	FS-50A
FORGE-36	FORGE-36A
FORGE-42	FORGE-42A
FORGE-50	FORGE-50A

Table 13.1. Approved Doors (Decorative Fronts)

**NOTE:** Figure 13.14 shows the minimum clearance from fireplace opening to adjacent finishing materials greater than one inch thick for operable doors. The 1-1/2 inch clearance will allow the doors to open to 90 degrees. Increasing clearance from the fireplace opening to the adjacent finishing materials will allow the doors to open past 90 degrees.

The doors approved for use with this appliance have been designed to be installed by two methods: Overlap Fit or Inside Fit. Before beginning the installation, it is important to determine with method will be used.

**Overlap Fit Doors:** These doors have been designed to be installed over finishing material up to one inch thick.

**Inside Fit Doors:** These doors may be recessed into non-combustible finishing material up to 6 inches thick.

**NOTICE:** Proper clearances from the fireplace opening to any finishing material thicker than 1 inch **MUST** be maintained.

**NOTE:** Finishing templates are included with this product. See Section 13.A.

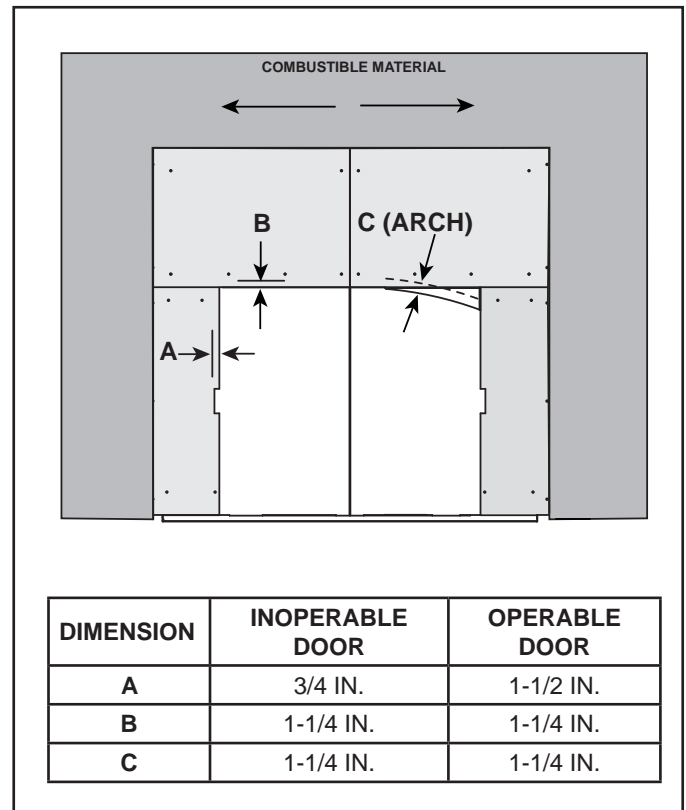

Figure 13.15 Inside Fit Doors

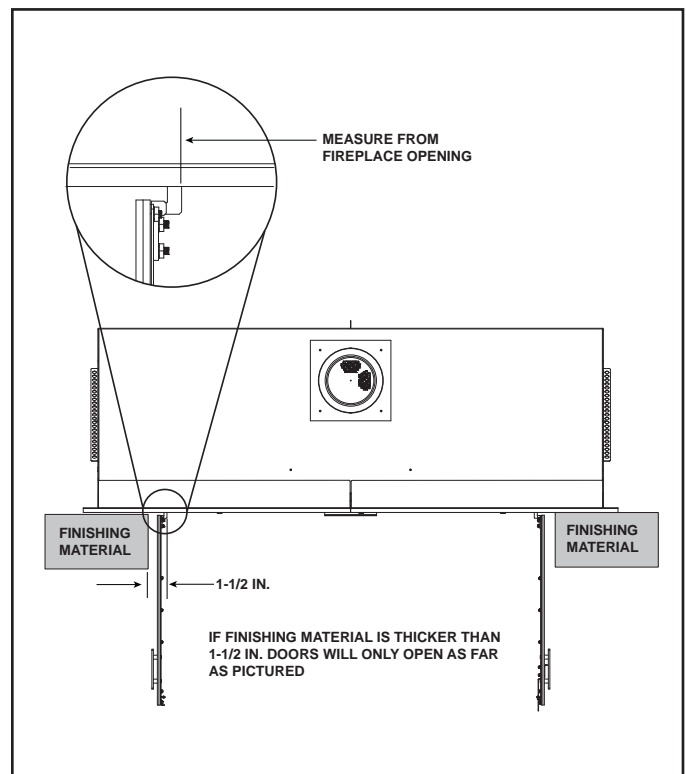

Figure 13.16 Minimum Side Clearance for Operable Doors

# 14 Appliance Setup

## A. Remove Fixed Glass Assembly

See Section 14.1.

## B. Remove the Shipping Materials

Remove shipping materials from inside or underneath the firebox.

## C. Clean the Appliance

Clean/vacuum any sawdust that may have accumulated inside the firebox or underneath in the control cavity.

## D. Accessories

Install approved accessories per instructions included with accessories. Contact your dealer for a list of approved accessories.

**WARNING! Risk of Fire and Electric Shock!** Use ONLY Hearth & Home Technologies-approved optional accessories with this appliance. Using non-listed accessories could result in a safety hazard and will void the warranty.

## E. Install Teco-Sil and Mystic Embers

1. Install Teco-Sil along front edge of glass as shown in Figure 14.1. Rock should follow contour cutout in the front refractory.



Figure 14.1. Install Teco-Sil

2. Fill in the rest of the ember glass area by placing an even layer of Teco-Sil across the bottom. Dropping the Teco-Sil through the oval holes in the burner creates a more even layer. See Figure 14.2.
3. Using a high temperature black paint, fog the Teco-Sil to the desired look. See Figure 14.3. Prior to painting, take precautions to prevent any overspray from reaching the pilot assembly.

**NOTICE:** Do NOT paint the pilot assembly!



Figure 14.2. Ember Glass Area Covered with Teco-Sil



Figure 14.3. Teco-Sil Painted

4. Apply Mystic-Embers around the ember bed and hearth refractory. The joints in the front middle hearth refractory can be concealed with these embers.



Figure 14.4. Apply Mystic Embers

## F. Glowing Ember Placement

**WARNING! Risk of Explosion!** Follow ember placement instructions in manual. **DO NOT** place embers directly over burner ports. Replace ember material annually. Improperly placed embers interfere with proper burner operation.

Ember material is shipped with this gas appliance. To place the ember material:

- Embers **CANNOT** be placed directly over ports. Care should be taken not to cover the lighting trail of ports (from back to front).
- Place dime-size pieces of Glowing Embers® just in front of the port trail, but not on or in between the ports (see Figure 14.5). Care should be taken so that the ports are not covered. Failure to follow this procedure will likely cause lighting and sooting problems.
- Save the remaining ember materials for use during appliance servicing. The embers provided should be enough for 3 to 5 applications.

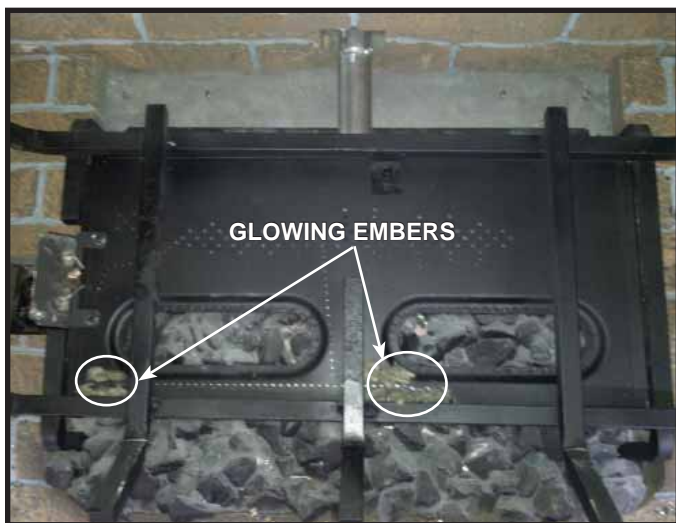

Figure 14.5. Location of Glowing Embers

## G. LED's

LED's are factory installed. No additional set up or activation required.

- See section 3.A for maintenance and bulb replacement.

## H. Install the Log Assembly

Log Set Assembly: LOGS-TRUE36  
LOGS-TRUE42

Models: TRUE-36C, TRUE-36H, TRUE-36S  
TRUE-42C, TRUE-42H, TRUE-42S

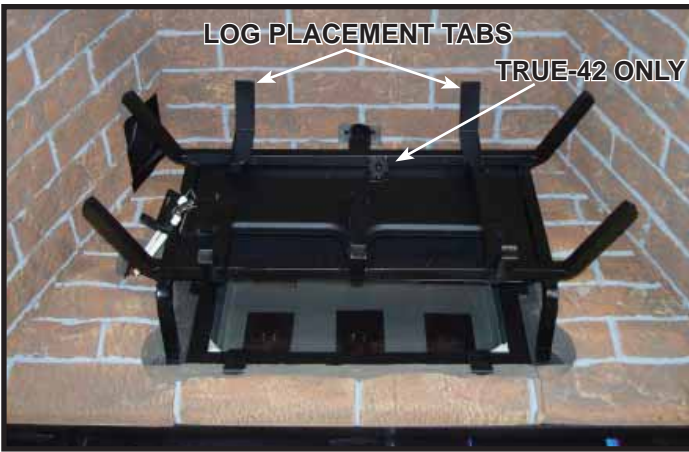

Figure 1.

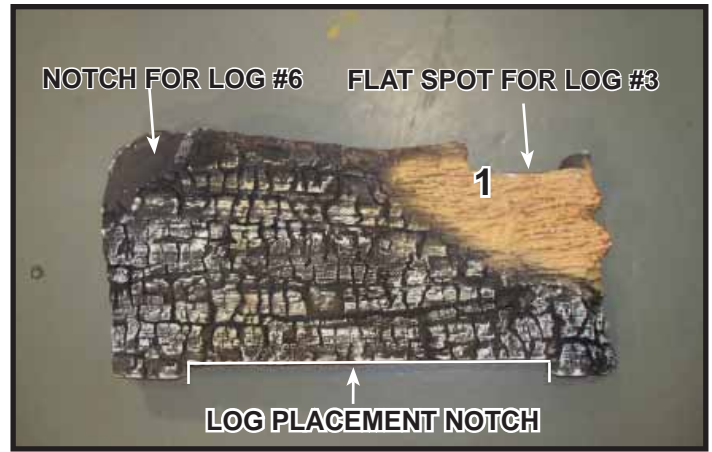

Figure 2.

**CAUTION:** Logs are fragile, handle with care. **Log #1 (2280-701 for TRUE-36, 2281-701 FOR TRUE-42):** Locate log placement notch on the bottom of log #1. See Figure 2. Mate outer notches on the bottom of Log #1 with the left and right grate tines. Slide Log #1 toward the rear of appliance until back side of Log #1 contacts the log placement tabs. See Figures 1-3.



Figure 3.

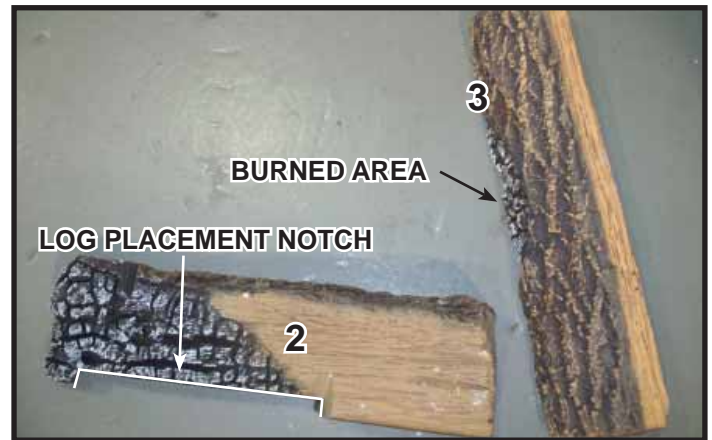

Figure 4.

**Log #2 (2280-702 for TRUE-36, 2281-702 for TRUE-42):** Locate log placement notch on the bottom of Log #2. See Figure 4. Mate notch on the bottom of Log #2 with the center and right grate tines. Slide log toward rear of appliance until right end contacts the side grate tine. See Figure 5.

**Log #2 (TRUE-36):** Log #2 will be about 1 inch from the back of the center grate tine when properly placed. See Figure 5.

**Log #2 (TRUE-42):** Log #2 will contact center log placement tab on center grate tine. See Figure 5.

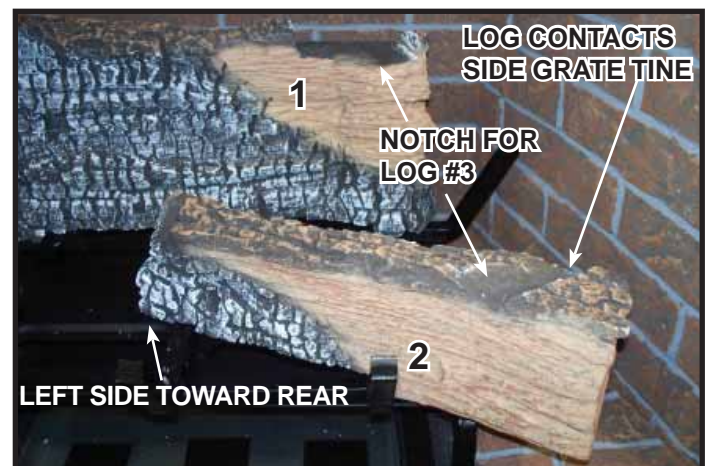

Figure 5.

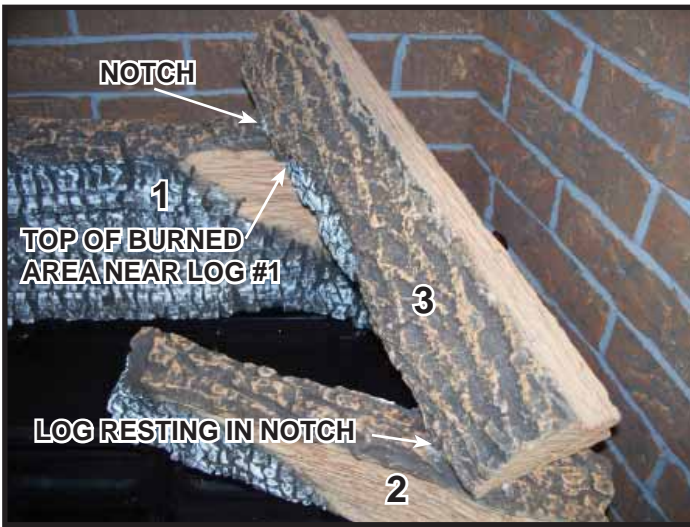

Figure 6.

**Log #3 (2281-703):** Locate log placement notches for Log #3. See Figure 5. Place Log #3 onto notches so that the bottom of the log rests in the notch on log #2 and the top rests in the left hand side of the notch on Log #1. The top of the burned area on Log #3 will be close to Log #1 when properly positioned. See Figure 6.

**Log #4 (2280-704 for TRUE-36; 2281-704 for TRUE-42):** See Figure 7. Place Log #4 between the left and center grate tines. Notches on log will rest on tines. Log should be positioned as far forward as possible. See Figure 8. Log #4 will lean against Log #2.

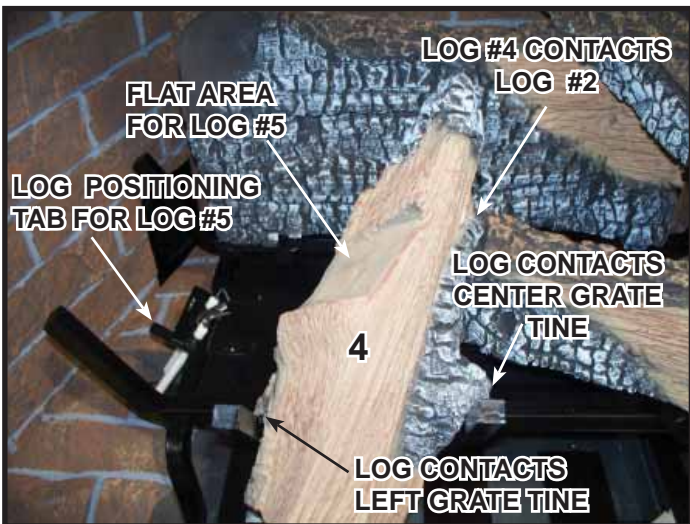

Figure 8.

**Log #5 (2280-705 FOR TRUE-36, 2281-705 FOR TRUE-42):** Locate flat area on Log #4 that will be used to position Log #5. See Figure 8. Place Log #5 into appliance as shown in Figure 9 or Figure 10. Left end of log should rest against left side refractory just in front of air inlet on rear, lower left of appliance.

**Log #5 (TRUE-36):** Log #5 will sit about halfway between front and rear grate tines, partially over pilot assembly. Log #5 will contact log positioning tab as shown in Figure 9. Right side of Log #5 will rest in notch on Log #4. See Figure 9.

**Log #5 (TRUE-42):** Log #5 will rest against the rear grate tine as shown in Figure 10. Right side of Log #5 will rest in notch on Log #4. See Figure 10.

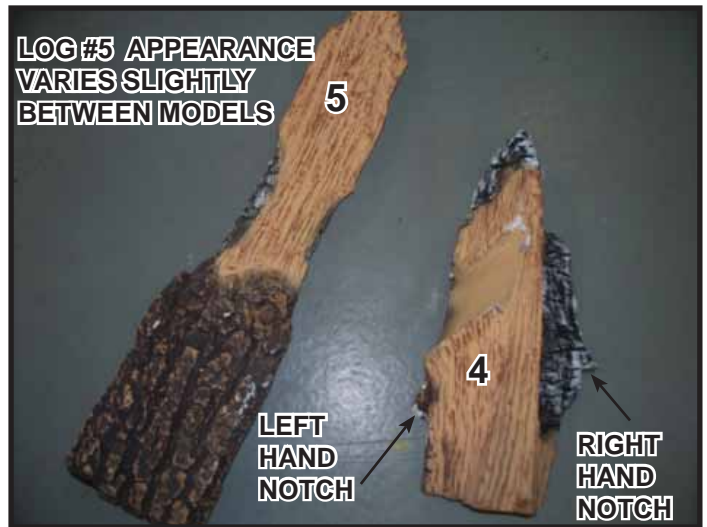

Figure 7.

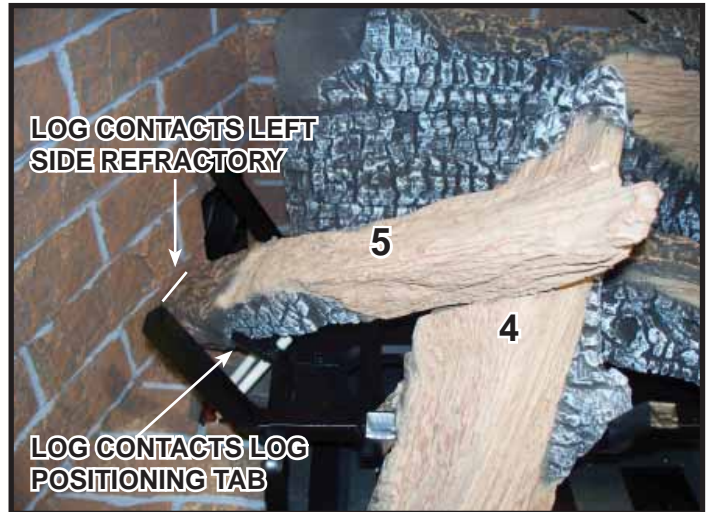

Figure 9. Log #5 - TRUE-36.



Figure 10. Log #5 - TRUE-42



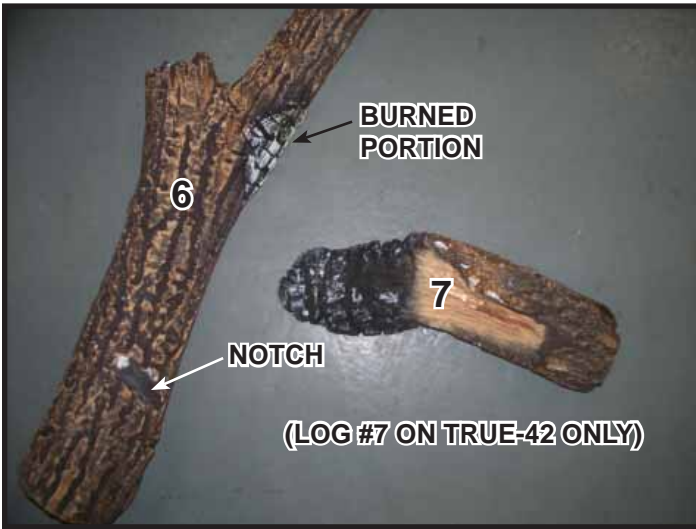

Figure 11.



Figure 12.

**Log #6 (2281-706):** Place Log #6 into appliance as shown in Figure 12. Base of log will sit on bottom refractory and notch on log will rest against grate tine. Lean top of log into notch on Log #1. See Figure 2.



Figure 13.

**Log #7 (2281-707 TRUE-42 ONLY):** Place Log #7 into appliance as shown in Figure 13. Right side of log should contact right refractory and burned portion of log should be centered between front and back tines.



Figure 14.

**Log #8 (2281-708):** Place Log #8 into appliance as shown in Figure 15. Left notch will contact left grate tine and base of log will rest on bottom refractory.

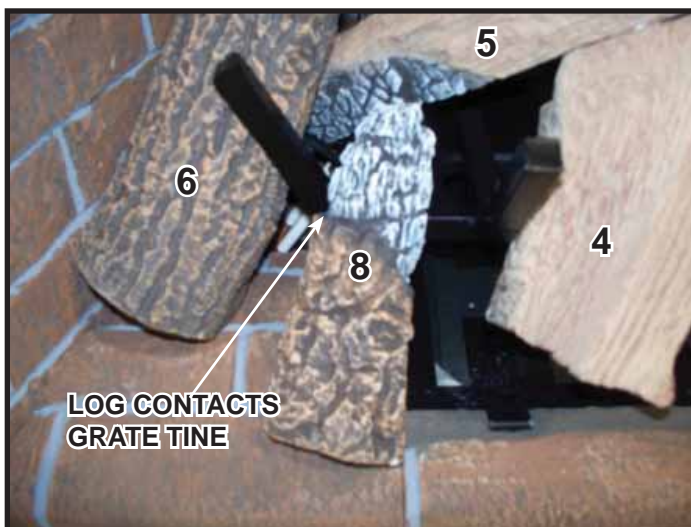

Figure 15.



Figure 16. Log Set Installed.

2281-935



Figure 1.

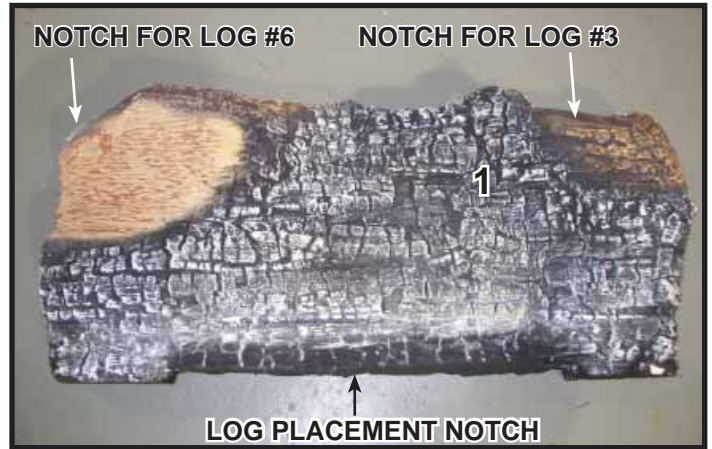

Figure 2.

**CAUTION:** Logs are fragile, handle with care. **Log #1 (2282-701):** Locate log placement notch on the bottom of Log #1. See Figure 2. Mate outer notches on the bottom of Log #1 with the left and right grate tines. Slide Log #1 toward the rear of appliance until back side of Log #1 contacts the log placement tabs shown in Figure 1. See Figure 3.

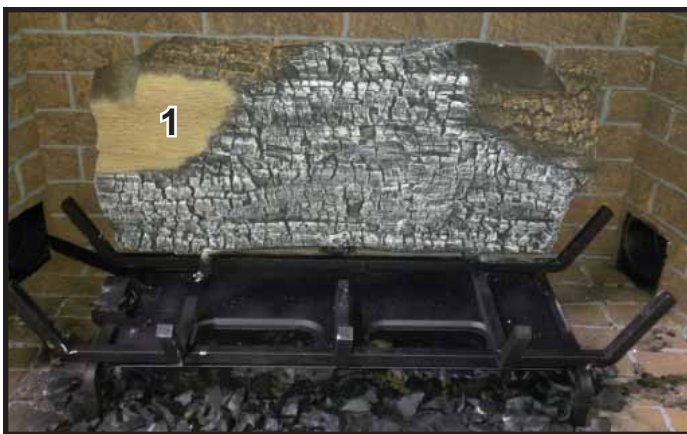

Figure 3.

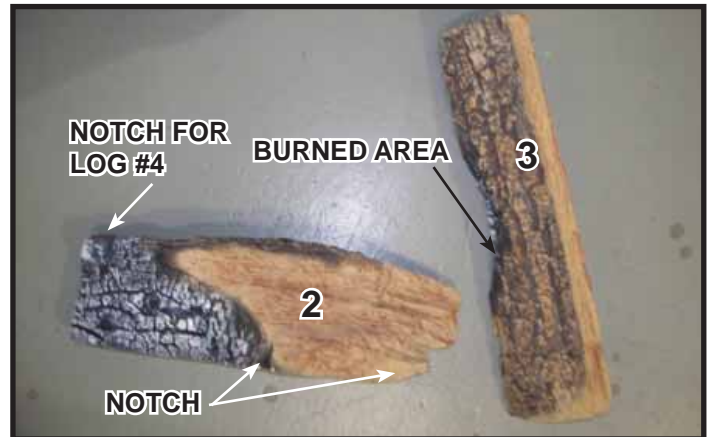

Figure 4.

**Log #2 (2282-702):** Locate log placement notches on the bottom of Log #2. See Figure 4. Mate notches on the bottom of Log #2 as shown in Figure 5. Notch on front of log will contact right front grate tine and notch on right side of log will contact front inside corner of side grate tine.

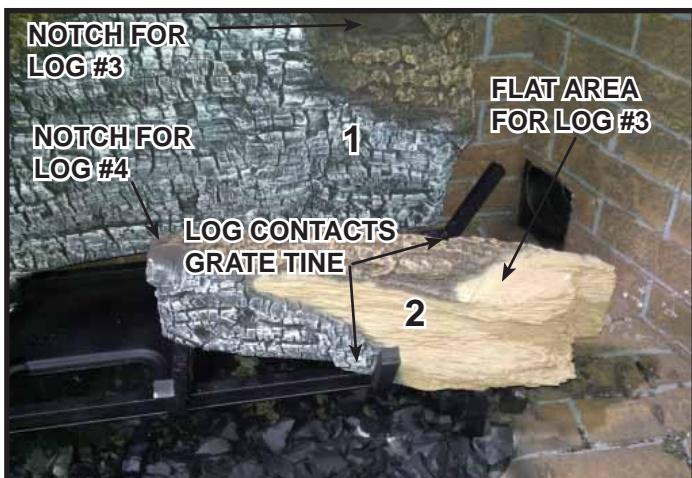

Figure 5.



Figure 6.

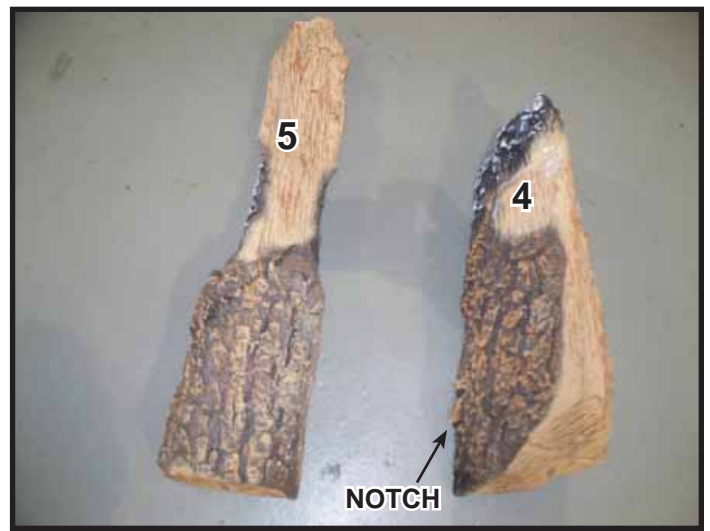

Figure 7.

**Log #3 (2282-703):** Locate log placement areas for Log #3. See Figure 5. Place Log #3 into notch on Log #1 so that the base rests on the flat area of log #2. The top of the burned area on Log #3 will be close to Log #1 when properly positioned. See Figure 6.

**Log #4 (2282-704):** See Figure 7. Place Log #4 between the left and center grate tines. The base of Log #4 should rest on the refractory. Notch on log will rest on the front left grate tine and the top of log will rest in notch on Log #2. See Figure 8.

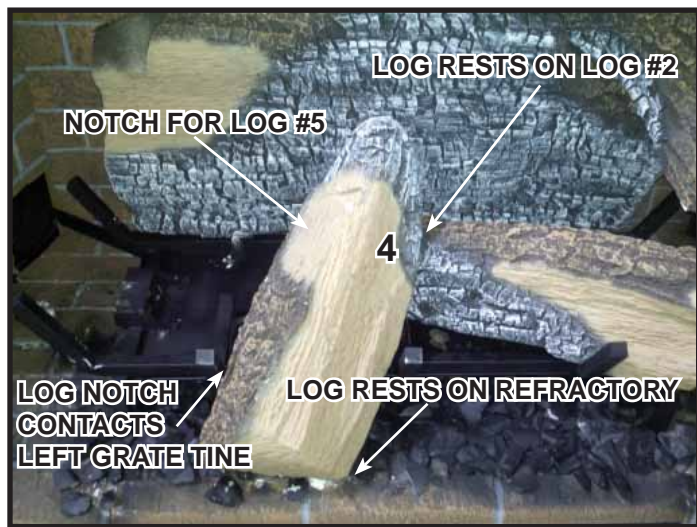

Figure 8.

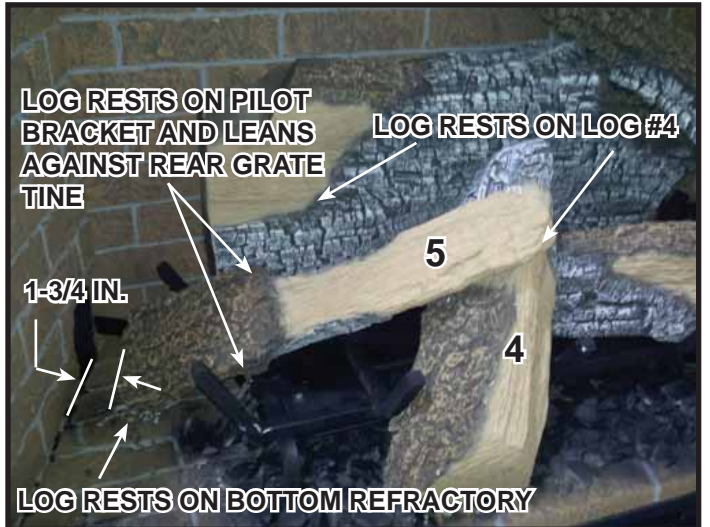

Figure 9.

**Log #5 (2281-705):** Locate flat area on Log #4 that will be used to position Log #5. See Figure 8. Place Log #5 into appliance as shown in Figure 9. The left side of the log will rest on bottom refractory and pilot bracket. It will also lean against rear grate tine. The right side of Log #5 will rest in notch on Log #4. There will be a space approximately 1-3/4 inches from the end of the log to the left side refractory.

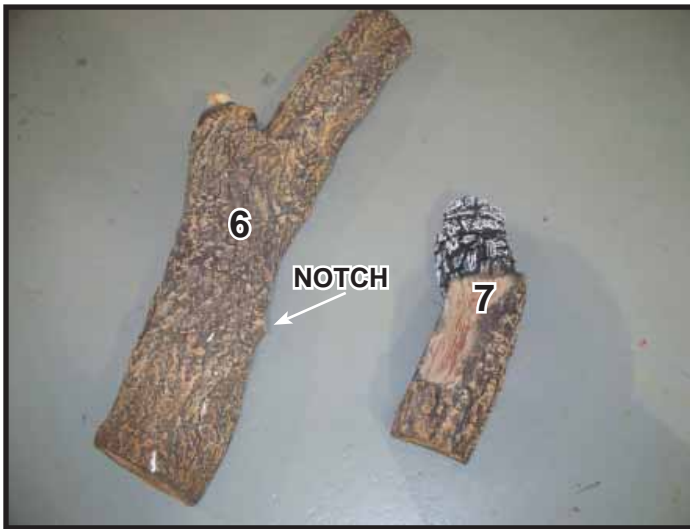

Figure 10.

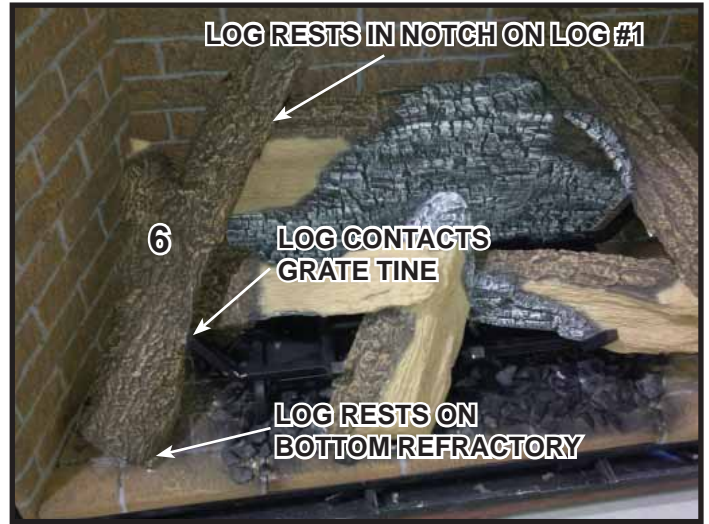

Figure 11.

**Log #6 (2282-706):** Place Log #6 into appliance as shown in Figure 11. Base of log will sit on bottom refractory and notch on log will rest against grate tine. Lean top of log into notch on Log #1. See Figure #2.



Figure 12.



Figure 13.

**Log #7 (2281-707):** Place Log #7 into appliance as shown in Figure 12. Right side of log should contact right refractory and burned portion of log should be centered between front and back tines.

**Log #8 (2281-708):** Place Log #8 into appliance as shown in Figure 14. Left notch will contact left grate tine and base of log will rest on bottom refractory.



Figure 14.



Figure 15. Log Set Installed.

2282-935

## I. Fixed Glass Assembly

**WARNING! Risk of Asphyxiation!** Handle fixed glass assembly with care. Inspect the gasket to ensure it is undamaged and inspect the glass for cracks, chips or scratches.

- **DO NOT** strike, slam or scratch glass.
- **DO NOT** operate fireplace with glass removed, cracked, broken or scratched.
- Replace as a complete assembly.

**CAUTION! Risk of Injury!** Glass assembly installation and removal must be performed by a qualified service technician. See chart below for glass assembly weights.

- **TRUE-42 AND TRUE-50 MODELS:** It is recommended that Glass installation and removal be performed by two qualified service technicians.

Glass Weights		
TRUE-36	TRUE-42	TRUE-50
32 lbs	41 lbs	54 lbs

**CAUTION! Risk of Cuts or Abrasions.** Wear protective gloves and safety glasses during installation. Sheet metal edges are sharp.

### Removing Fixed Glass Assembly

This fixed glass assembly is held in place by lower glass clips, side clips and top retaining rail. To remove clips, engage the spring clips with the tool and pull tool out slightly.

1. The glass clip removal/installation tool is fastened to the lower right corner of the appliance. Remove tool by removing one screw. See Figure 14.6. If glass clip removal tool becomes misplaced, a cotter pin removal tool may be used.

**NOTICE:** Protect and prevent the hearth from damage by covering it with a drop cloth.



Figure 14.6. Glass Clip Tool



Figure 14.7. Glass Clip Tool Location

2. To disengage bottom glass clips, position the glass clip removal/installation tool parallel to the floor and insert it about two inches into the gap between the glass frame and the front bottom fireplace lip. Insert the tool on the lower left side of the glass clip and move to the right to engage the clip. Using one motion, pull out slightly while pushing down to disengage bottom glass clip. Repeat for the other bottom spring clips. There are three on the TRUE-36 and four on the TRUE-42 and TRUE-50. See Figure 14.7 and Figure 14.8.



Figure 14.8. Inserting Glass Clip Tool

3. Disengage the left and right glass clips one at a time using the glass clip removal/installation tool. Insert tool from the top side of the side glass clip. Pull the glass tool out slightly to disengage the side clip. See Figure 14.12.
4. Grasp the left and right sides of the glass assembly and carefully pull outward to remove the bottom from the support tabs on the bottom glass clips. Lower the glass to remove it from the top retainer rail.

**CAUTION! Risk of Injury! DO NOT** put fingers under glass frame. Fingers may get pinched by glass frame during removal.

## Replacing Fixed Glass Assembly

This fixed glass assembly is held in place by two side clips, one top retaining rail and lower glass clips. The TRUE36 has three lower glass clips and the TRUE42 and TRUE50 have four lower glass clips. To remove clips, engage the spring clips with the tool and pull tool out slightly. Rotate wrist left and right to disengage clip. The glass clip tool is shown in Figure 14.6.

1. Tool is fastened to the lower right corner of the fireplace. Remove tool by removing one screw. If glass clip removal tool becomes misplaced, a cotter pin removal tool may be used.
2. Position the fixed glass assembly so that it is about eight inches from the face of the appliance. See Figure 14.9. An arch door application will require the glass to be installed at a steeper angle.



Figure 14.9 Positioning Glass

3. Center the fixed glass assembly from left to right inside the top of the appliance opening.

The glass frame has tabs on the bottom that coincide with the bottom glass clip location. The TRUE-36 has three tabs and the TRUE-42 and TRUE-50 have four tabs. If the glass is not centered, it cannot be installed properly. Align the notch at the top center of the glass frame assembly with the notch on the top retaining rail. See Figure 14.10.

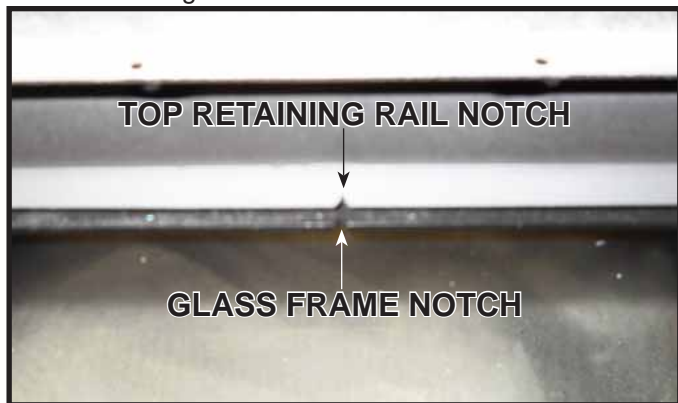

Figure 14.10. Align Notches

4. Install fixed glass assembly by lifting it up and sliding it into the top retaining rail. Grasp the fixed glass assembly on the sides.

**CAUTION! Risk of Injury! DO NOT** put fingers under glass frame. Fingers may get pinched by glass frame during installation.

Once the glass is installed tightly into the top retaining rail, push in the bottom so that the glass assembly rests on the support tabs on the glass clip. See Figure 14.11.

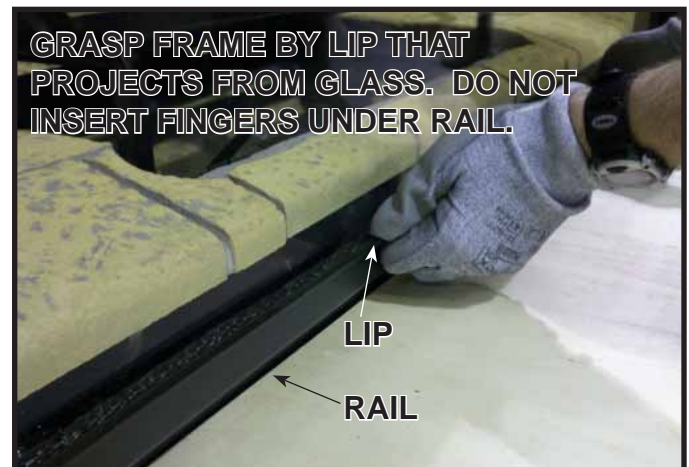

Figure 14.11. Installing Glass

5. Ensure the fixed glass assembly is situated tight against the firebox face. Engage the left and right glass clips using the glass clip tool. See Figure 14.12.



Figure 14.12. Securing Side Glass Clips

6. Once the left and right glass clips are installed, engage the bottom clips by inserting the glass clip tool at a sharp downward angle to get between the gap between the glass frame and the front bottom fireplace lip. See Figure 14.13.

7. Return glass tool to its shipping location in the lower right corner of the appliance and secure with one screw.



Figure 14.13. Securing Bottom Glass Clips

## J. Air Shutter Setting

Air shutter settings should be adjusted by a qualified service technician at the time of installation. The air shutter is set at the factory for minimum vertical vent run. Adjust air shutter for longer vertical runs. See Figure 14.14.

### Flame Appearance

- After 15 minutes, the flame will be a yellow/blue mix. The front flames may be blue at this time.
- After 30 minutes, the flame should be yellow with some blue flame near the burner ports.
- After 1 hour, the flame will be at its maximum maturity.

**Note:** Visually, a propane flame may differ from a natural gas flame. This is due to the different chemical compositions that make up both fuel types. In general, the LP flames may be a little shorter and much brighter than a natural gas flame.

To adjust air shutter:

- Loosen the screw on the burner assembly.
- The air shutter should only be adjusted in increments of 1/8 in.
- To close the air shutter, turn shutter clockwise.
- To open air shutter, turn shutter counterclockwise.
- Tighten the screw.

**NOTICE:** Flame should not appear orange or stretch to the top refractory. If sooting occurs, provide more air by opening the air shutter.



Figure 14.14 Air Shutter

### Air Shutter Settings

MODEL	NG	LP
TRUE-36	1/2 in.	Full Open
TRUE-42	11/16 in.	Full Open
TRUE-50	5/8 in.	Full Open

# 15 Troubleshooting

With proper installation, operation, and maintenance your gas appliance will provide years of trouble-free service. If you do experience a problem, this troubleshooting guide will assist a qualified service technician in the diagnosis of a problem and the corrective action to be taken. This troubleshooting guide can only be used by a qualified service technician. Contact your dealer to arrange a service call by a qualified service technician.

## A. IntelliFire Plus™ Ignition System

Symptom	Possible Cause	Corrective Action
1. Pilot won't light. The ignitor/module makes noise, but no spark.	A. Incorrect wiring.	Verify "S" wire (white) for sensor and "I" wire (orange) for ignitor are connected to correct terminals on module and pilot assembly.
	B. Loose connections or electrical shorts in the wiring.	Verify no loose connections or electrical shorts in wiring from module to pilot assembly. Verify connections underneath pilot assembly are tight; also verify igniter and flame sense wires are not grounding out to metal chassis, pilot burner, pilot enclosure, mesh screen if present, or any other metal object.
	C. Ignitor gap is too large.	Verify gap of igniter to right side of pilot hood. The gap should be approximately .17 in. or 1/8 in. (3 mm).
2. Pilot won't light, there is no noise or spark.	A. No power, transformer installed incorrectly, or depleted batteries.	Verify that transformer is installed and plugged into module. Check voltage of transformer at connection to module. Acceptable readings of a good transformer are between 6.4 and 6.6 volts AC. Battery power supply voltage must be at least 4 volts. If less than 4 volts, replace batteries.
	B. A shorted or loose connection in wiring configuration or wiring harness.	Remove and reinstall the wiring harness that plugs into module. Verify there is a tight fit. Verify pilot assembly wiring to module. Remove and verify continuity of each wire in wiring harness. Replace any damaged components.
	C. Improper wall switch wiring.	Verify that 110/VAC power is "ON" to junction box.
	D. Module not grounded.	Verify black ground wire from module wire harness is grounded to metal chassis of appliance.
3. Pilot sparks, but Pilot will not light.	A. Gas supply.	Verify that incoming gas line ball valve is "open". Verify that inlet pressure reading is within acceptable limits.
	B. Ignitor gap is too large.	Verify gap of igniter to right side of pilot hood. The gap should be approximately .17 in. or 1/8 in. (3 mm).
	C. Module is not grounded.	Verify module is securely grounded to metal chassis of appliance.
	D. Pilot valve solenoid.	Verify that 1.5 to 1.8 VDC is supplied to pilot solenoid from module. If below 1.5 volts, replace module. If 1.5 volts or greater, replace valve.



## Troubleshooting (continued)

Symptom	Possible Cause	Corrective Action
4. Pilot lights but continues to spark, and main burner will not ignite. (If the pilot continues to spark after the pilot flame has been lit, flame rectification has not occurred.)	A. A shorted or loose connection in flame sensing rod.	Verify all connections to wiring diagram in manual. Verify connections underneath pilot assembly are tight. Verify flame sense or igniter wires are not grounding out to metal chassis, pilot burner, pilot enclosure or screen if present, or any other metal object.
	B. Poor flame rectification or contaminated flame sensing rod.	With fixed glass assembly in place, verify that flame is engulfing flame sensing rod on left side of pilot hood. Flame sensing rod should glow shortly after ignition. With a multi-meter, verify that current in series between module and sense lead is at least 0.14 microamps. Verify correct pilot orifice is installed and gas inlet is set to pressure specifications. Polish flame sensing rod with fine steel wool to remove any contaminants that may have accumulated on flame sensing rod.
	C. Module is not grounded.	Verify module is securely grounded to metal chassis of appliance. Verify that wire harness is firmly connected to the module.
	D. Damaged pilot assembly or contaminated flame sensing rod.	Verify that ceramic insulator around the flame sensing rod is not cracked, damaged, or loose. Verify connection from flame sensing rod to white sensor wire. Polish flame sensing rod with fine steel wool to remove any contaminants that may have accumulated on flame sensing rod. Verify continuity with a multi-meter with ohms set at lowest range. Replace pilot if any damage is detected.
5. Appliance lights and runs for a few minutes and then shuts down and/or appliance cycles on and off.	A. A shorted or loose connection in flame sensing rod.	Verify all connections to wiring diagram in manual. Verify connections underneath pilot assembly are tight. Verify flame sense or igniter wires are not grounding out to metal chassis, pilot burner, pilot enclosure or screen if present, or any other metal object.
	B. Poor flame rectification or contaminated flame sensing rod.	With fixed glass assembly in place, verify that flame is engulfing flame sensing rod on left side of pilot hood. Flame sensing rod should glow shortly after ignition. With a multi-meter, verify that current in series between module and sense lead is at least 0.14 microamps. Verify correct pilot orifice is installed and gas inlet is set to pressure specifications. Polish flame sensing rod with fine steel wool to remove any contaminants that may have accumulated on flame sensing rod.
	C. Logs are set up incorrectly.	Remove and reinstall logs per the log placement instructions.
	D. Damaged pilot assembly or contaminated flame sensing rod.	Verify that ceramic insulator around the flame sensing rod is not cracked, damaged, or loose. Verify connection from flame sensing rod to white sensor wire. Polish flame sensing rod with fine steel wool to remove any contaminants that may have accumulated on flame sensing rod. Verify continuity with a multi-meter with ohms set at lowest range. Replace pilot if any damage is detected.

# 16 Reference Materials

## A. Appliance Dimension Diagram

Dimensions are actual appliance dimensions. Use for reference only. For framing dimensions and clearances refer to Section 5.

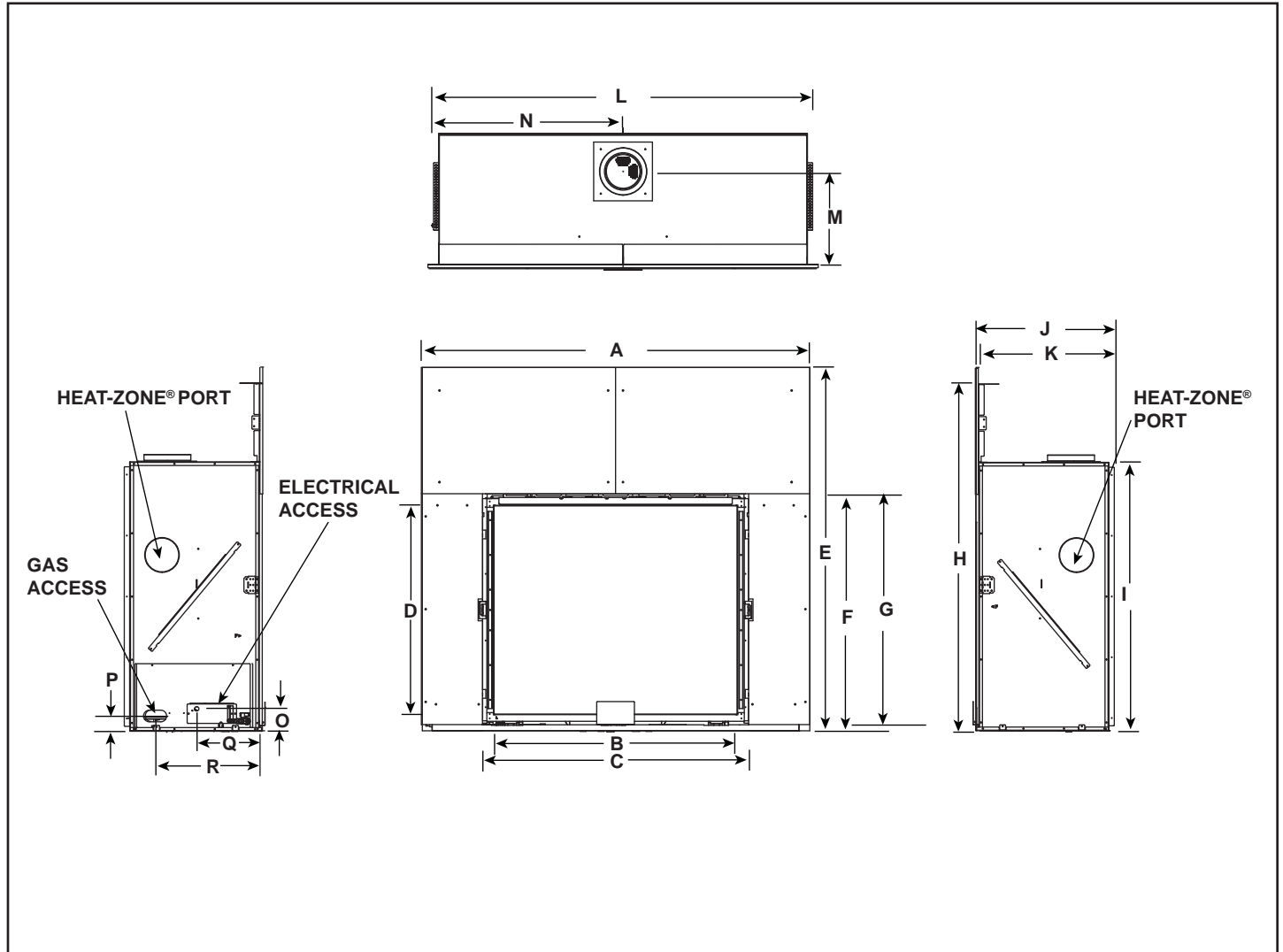

Appliance Dimensions Table TRUE-36

Location	Inches	Millimeters
A	61	1549
B	35-7/8	911
C	39-7/8	1013
D	31-1/16	789
E	57-5/8	1464
F	35-3/16	894
G	34-3/16	868
H	54-15/16	1395
I	41-3/8	1051

Location	Inches	Millimeters
J	24	610
K	23-1/2	597
L	59-1/4	1505
M	16	406
N	29-5/8	752
O	3-7/8	98
P	2-3/4	70
Q	10-7/8	276
R	16-1/8	410

Figure 16.1 Appliance Dimensions (TRUE-36)

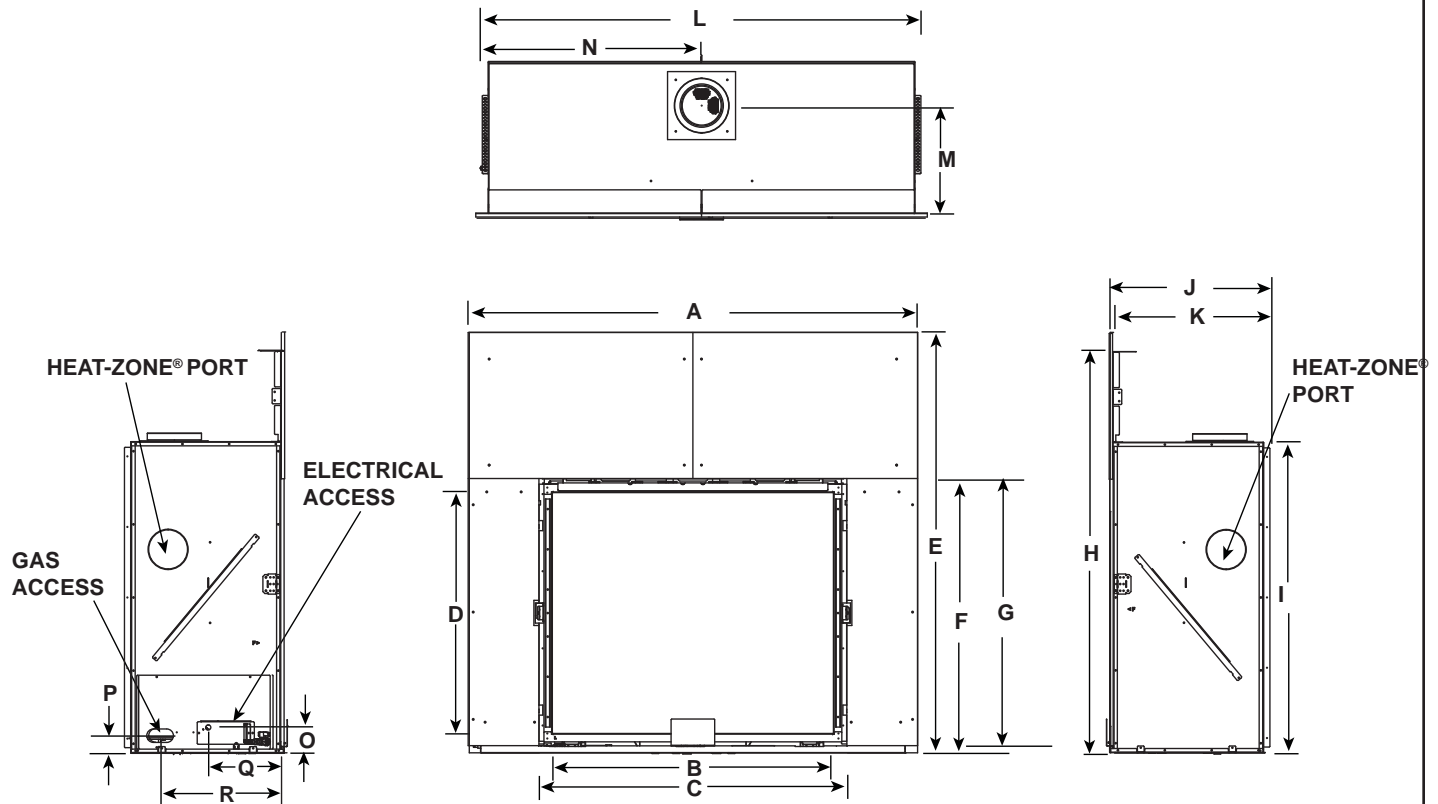

Appliance Dimensions Table TRUE-42

Location	Inches	Millimeters
A	67	1702
B	41-7/8	1064
C	45-7/8	1165
D	36-1/16	916
E	62-5/8	1591
F	40-3/16	1021
G	39-3/16	995
H	59-15/16	1522
I	46-3/8	1178

Location	Inches	Millimeters
J	24	610
K	23-1/2	597
L	65-5/16	1659
M	16	406
N	32-11/16	830
O	3-7/8	98
P	2-3/4	70
Q	10-7/8	276
R	16-1/8	410

Appliance Dimensions Table TRUE-50

Location	Inches	Millimeters
A	75	1905
B	49-7/8	1267
C	53-7/8	1368
D	40-1/16	1018
E	66-5/8	1692
F	44-3/16	1122
G	43-3/16	1097
H	63-15/16	1624
I	50-3/8	1280

Location	Inches	Millimeters
J	24	610
K	23-1/2	597
L	73-5/16	1862
M	16	406
N	36-11/16	932
O	3-7/8	98
P	2-3/4	70
Q	10-7/8	276
R	16-1/8	410

Figure 16.2 Appliance Dimensions (TRUE-42 & TRUE-50)

## B. Vent Components Diagrams

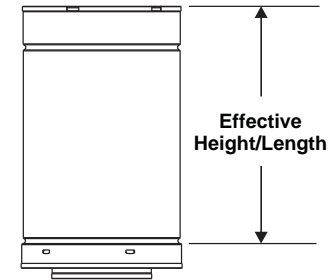

DVP Pipe (see chart)

Pipe	Effective Length	
	Inches	Millimeters
DVP4	4	102
DVP6	6	152
DVP12	12	305
DVP24	24	610
DVP36	36	914
DVP48	48	1219
DVP6A	3 to 6	76 to 152
DVP12A	3 to 12	76 to 305
DVP12MI	3 to 12	76 to 305
DVP24MI	3 to 24	76 to 610

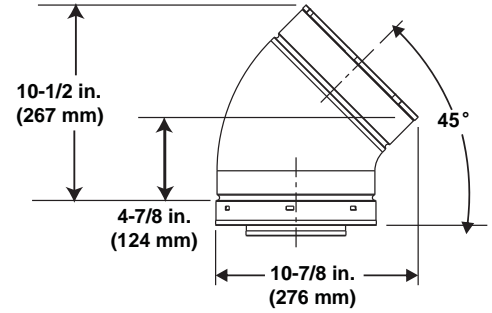

DVP45 (45° Elbow)

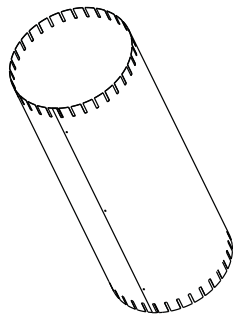

Assembled  
Height: 24 in./610 mm  
Diameter: 10 in./254 mm

DVP-AS2

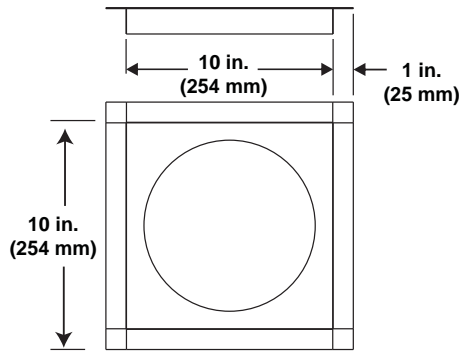

DVP-FS (Ceiling Firestop)

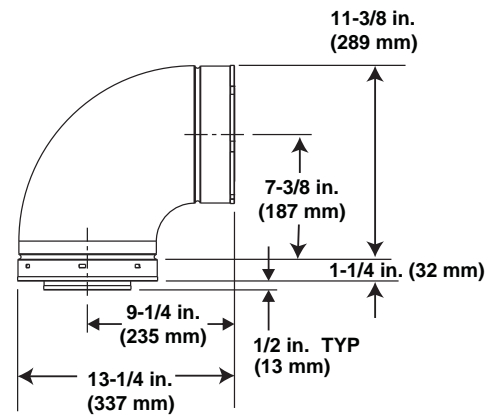

DVP90ST (90° Elbow)

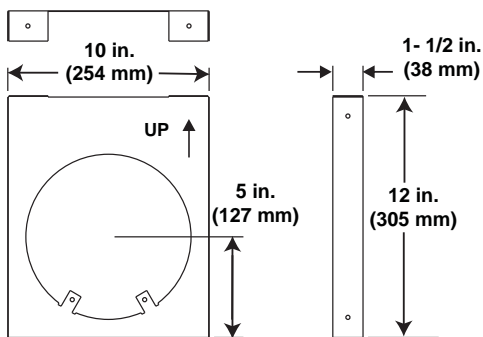

DVP-HVS (Vent Support)

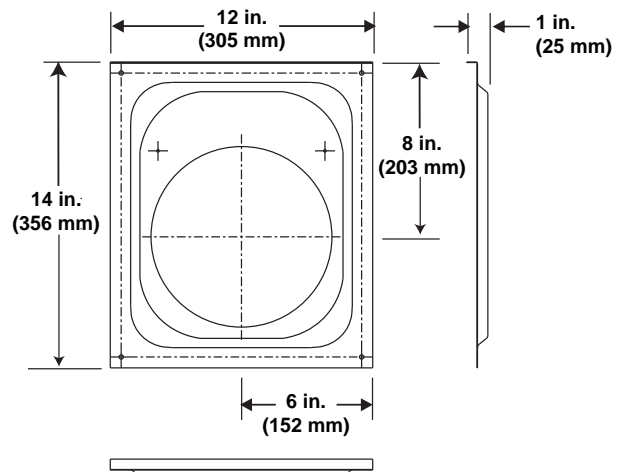

DVP-WS (Wall Shield Firestop)

Figure 16.3 DVP vent components

## B. Vent Components Diagrams (continued)

Note: Heat shields MUST overlap by a minimum of 1-1/2 in. (38 mm). **The heat shield is designed to be used on a wall 4 in. to 7-1/4 in. (102 mm to 184 mm) thick.** If wall thickness is less than 4 in. (102 mm) the existing heat shields must be field trimmed. If wall thickness is greater than 7-1/4 in. (184 mm) a DVP-HSM-B will be required.

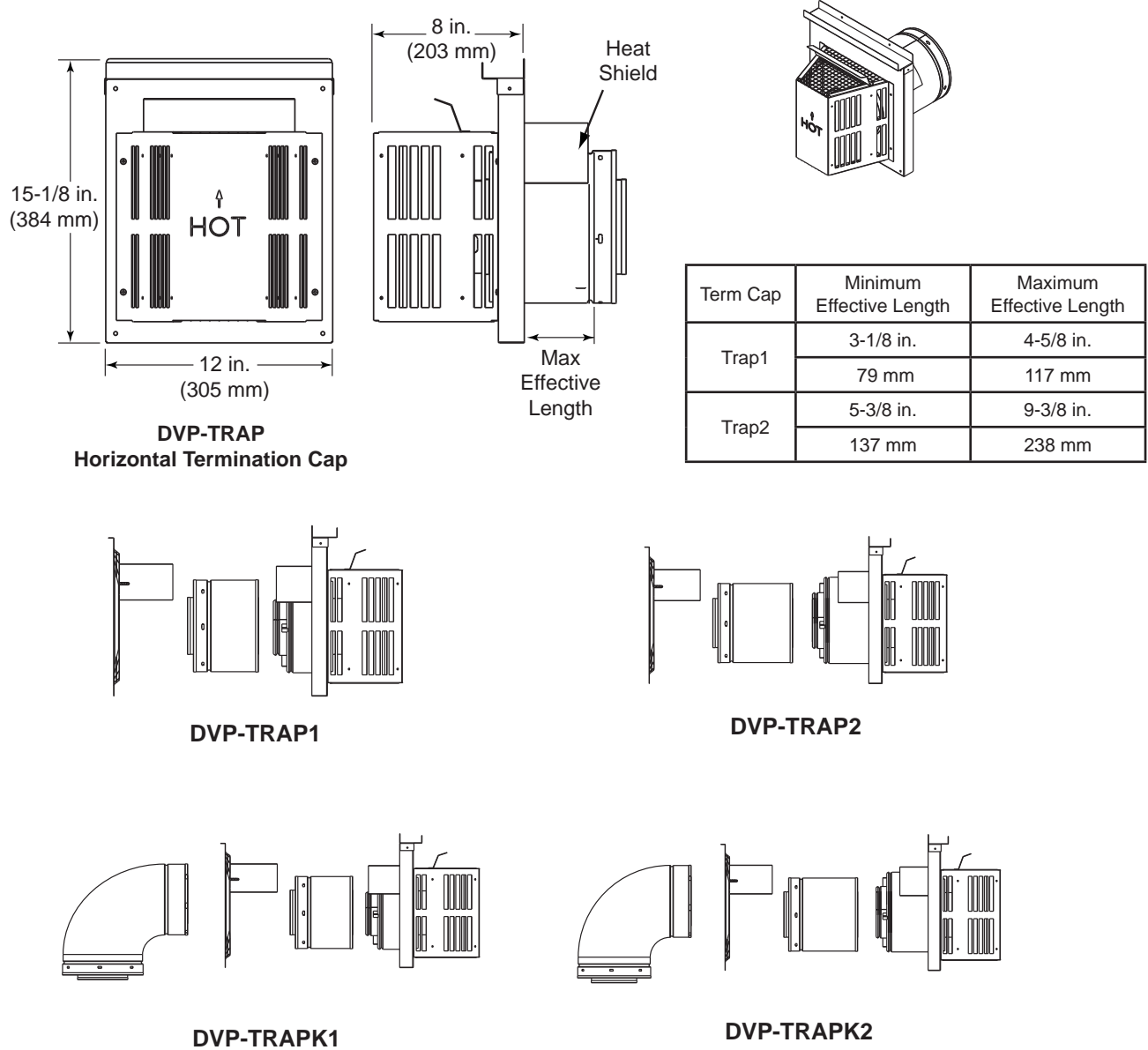
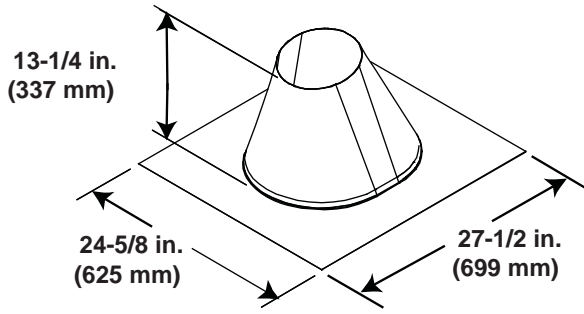
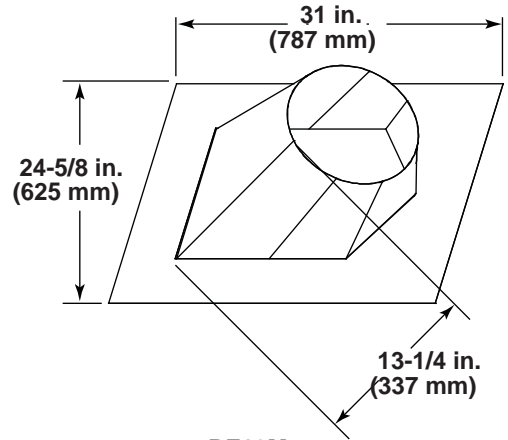

Figure 16.4 DVP vent components

**B. Vent Components Diagrams (continued)**



**RF6M**  
Roof Flashing Multi-pak



**RF12M**  
Roof Flashing Multi-pak

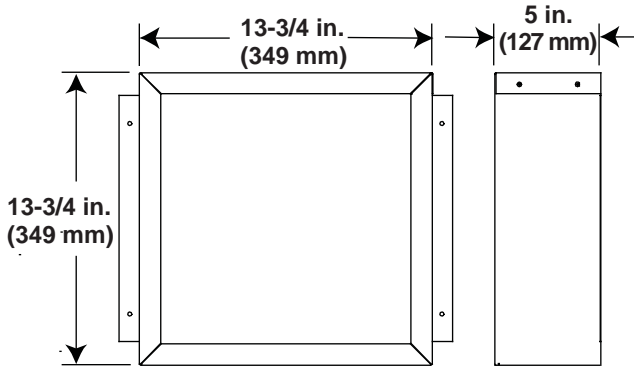

**BEK**  
Trap Cap Brick Extension

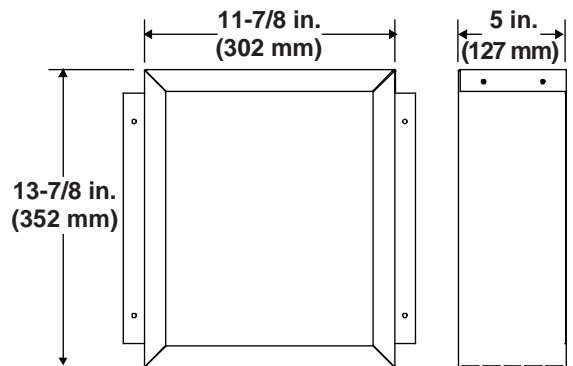

**DVP-BEK2**  
DVP-HPC Cap Brick Extension

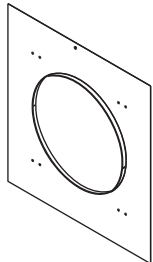

**DVP-TRAPFL**  
Flashing

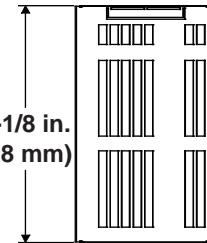
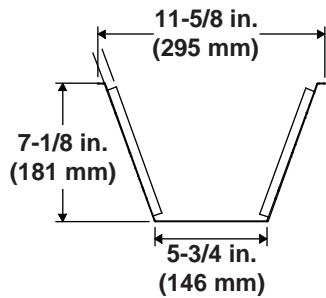

**COOL-ADD**  
Cap Shield

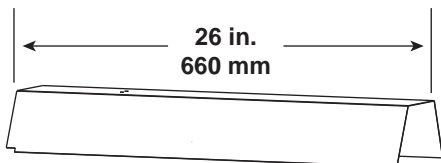
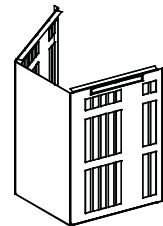

**DVP-HSM-B**  
Extended Heat Shield

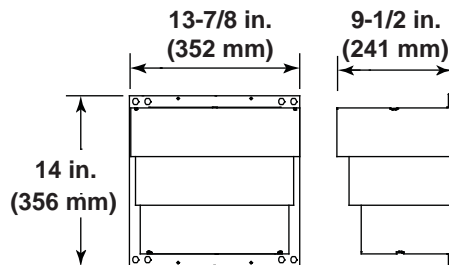

**DRC-RADIUS**  
Cap Shield

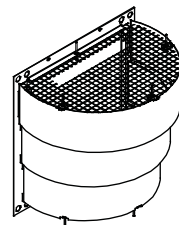
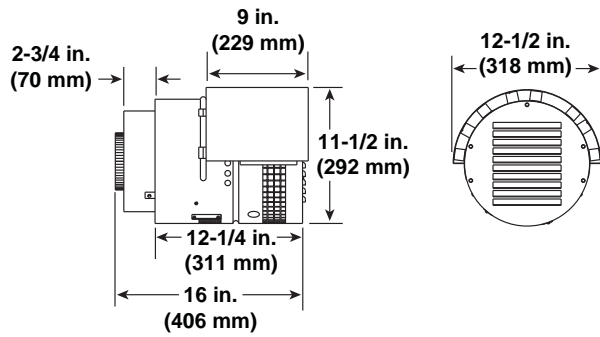
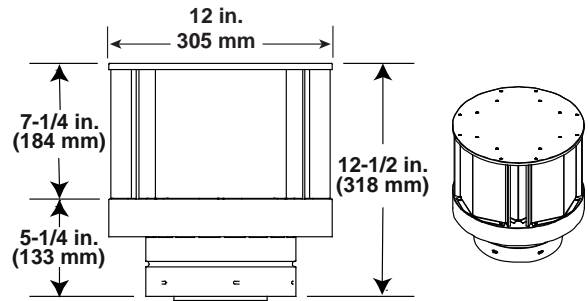

Figure 16.5 DVP vent components

## B. Vent Components Diagrams (continued)



**PVK-80**  
(Approved for TRUE-36, TRUE-42, TRUE-50)



**DVP-TVHW**  
Vertical Termination Cap (Highwind)

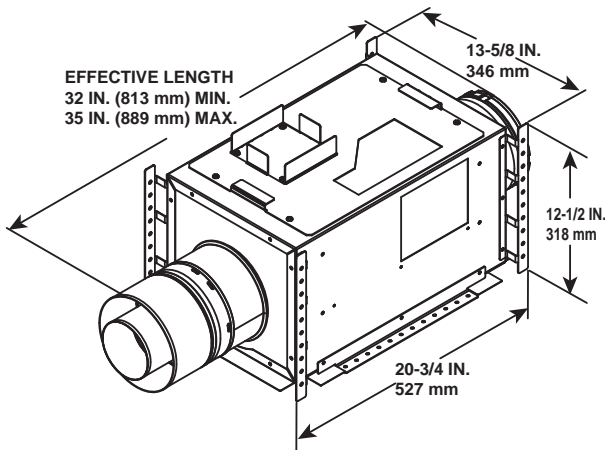

(Approved for TRUE-36 and TRUE-42 only)

**PVI-SLP**  
Power Vent Inline

Optional Wire Harness	
DESCRIPTION	PART NUMBER
10 ft. PV Wire Harness	PVI-WH10
20 ft. PV Wire Harness	PVI-WH20
40 ft. PV Wire Harness	PVI-WH40
60 ft. PV Wire Harness	PVI-WH60
80 ft. PV Wire Harness	PVI-WH80
100 ft. PV Wire Harness	PVI-WH100

**Note:** Wire harnesses required to power the PVI-SLP connect to the appliance and are ordered separately from PVI-SLP. Contact your dealer to order.

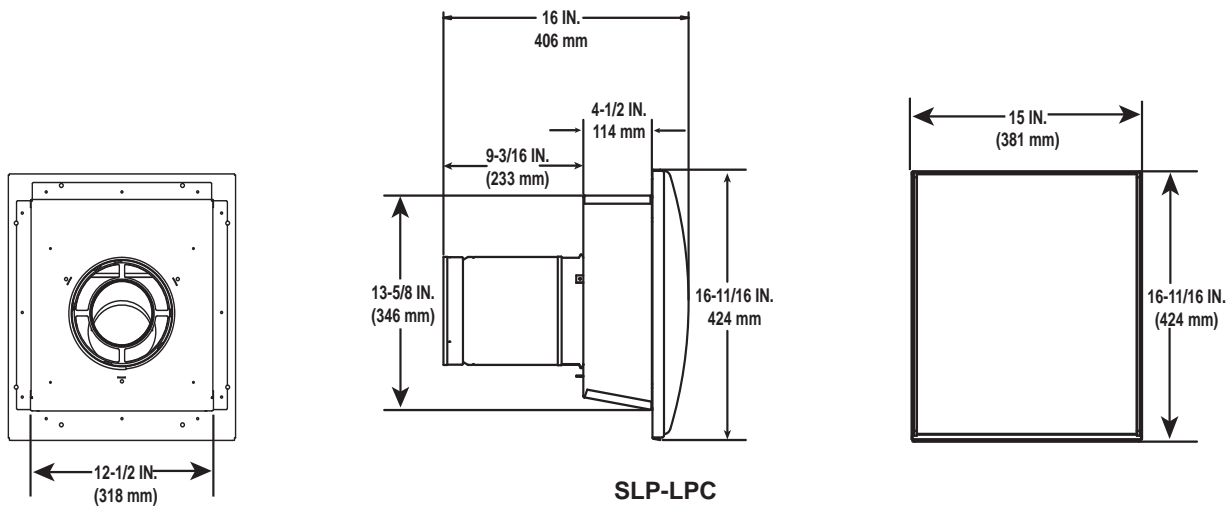

**SLP-LPC**  
SLP Low Profile Cap

Figure 16.6 Vent Components

### Log Set Assembly

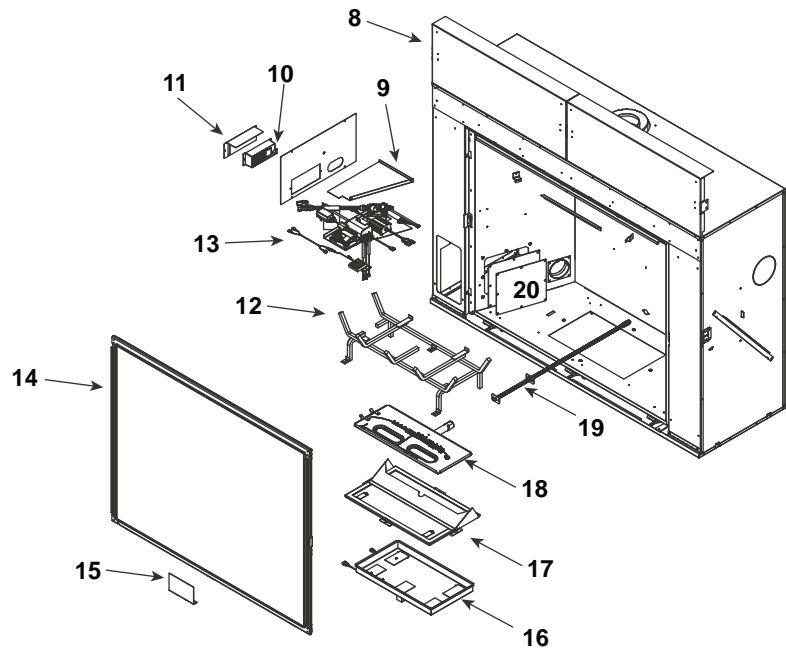
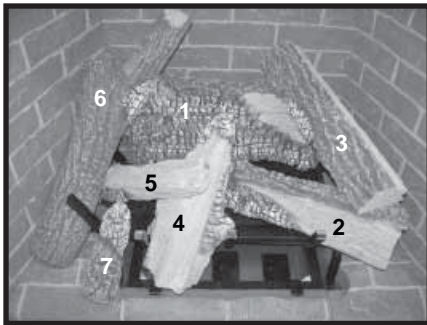

IMPORTANT: THIS IS DATED INFORMATION. When requesting service or replacement parts for your appliance please provide model number and serial number. All parts listed in this manual may be ordered from an authorized dealer.



**Stocked  
at Depot**

ITEM	DESCRIPTION	COMMENTS	PART NUMBER	
	Log Assembly		LOGS-TRUE36	Y
1	Log 1		SRV2280-701	
2	Log 2		SRV2280-702	
3	Log 3		SRV2281-703	
4	Log 4		SRV2280-704	
5	Log 5		SRV2280-705	
6	Log 6		SRV2281-706	
7	Log 7		SRV2281-708	
8	Heat Shield, Header	Qty 2 req	2280-105	
9	Heat Shield, Valve		2281-153	
10	Junction box		4021-013	Y
11	J-Box Bracket		2281-154	
12	Grate Assembly		2280-015	
13	Valve Assembly		<b>Refer to Valve Page</b>	
14	Glass Assembly		GLA-2280	Y
15	Finishing Spacer		2281-113	
16	LED Tub Assembly		2280-017	
17	Inner Glass Frame Assembly		2280-019	
18	Burner Assembly		2280-007	Y
19	Orifice Bracket Flex		2012-008	Y
20	Access Plate		2281-117	

Additional service parts on following page.

8/12



No one builds a better fire

Beginning Manufacturing Date: May 2012

Ending Manufacturing Date: Active

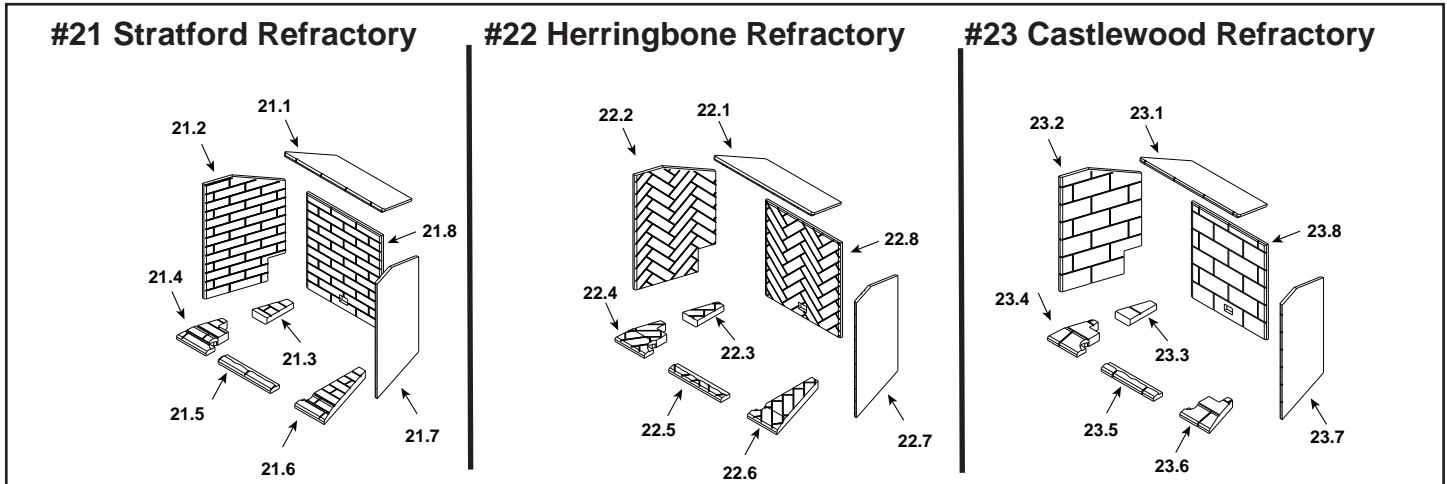

IMPORTANT: THIS IS DATED INFORMATION. When requesting service or replacement parts for your appliance please provide model number and serial number. All parts listed in this manual may be ordered from an authorized dealer.



**Stocked  
at Depot**

ITEM	DESCRIPTION	COMMENTS	PART NUMBER	
	Refractory, Stratford	TRUE-36S		
21.1	Refractory, Top		SRV2280-716	
21.2	Refractory, Left		SRV2280-713	
21.3	Refractory, Left Base		SRV2280-718	
21.4	Refractory, Left Base		SRV2280-711	
21.5	Refractory, Front Base		SRV2280-710	
21.6	Refractory, Right Base		SRV2280-712	
21.7	Refractory, Right		SRV2280-714	
21.8	Refractory, Back		SRV2280-715	
	Refractory, Herringbone	TRUE-36H		
22.1	Refractory, Top		SRV2280-726	
22.2	Refractory, Left		SRV2280-723	
22.3	Refractory, Left Base		SRV2280-728	
22.4	Refractory, Left Base		SRV2280-721	
22.5	Refractory, Front Base		SRV2280-720	
22.6	Refractory, Right Base		SRV2280-722	
22.7	Refractory, Right		SRV2280-724	
22.8	Refractory, Back		SRV2280-725	
	Refractory, Castlewood	TRUE-36C		
23.1	Refractory, Top		SRV2280-736	
23.2	Refractory, Left		SRV2280-733	
23.3	Refractory, Left Base		SRV2280-738	
23.4	Refractory, Left Base		SRV2280-731	
23.5	Refractory, Front Base		SRV2280-730	
23.6	Refractory, Right Base		SRV2280-732	
23.7	Refractory, Right		SRV2280-734	
23.8	Refractory, Back		SRV2280-735	

Additional service parts on following page.

### Log Set Assembly

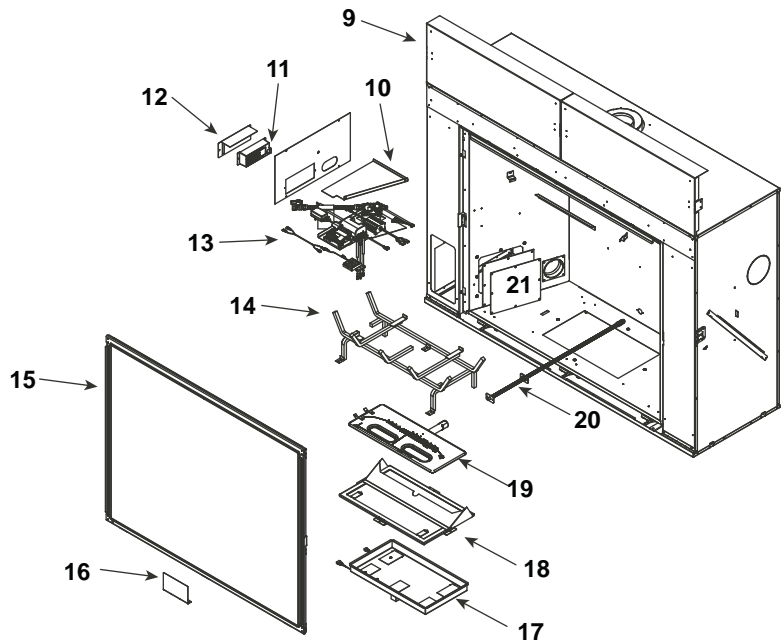
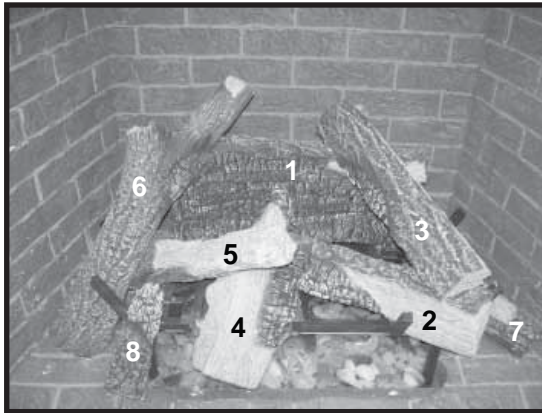

IMPORTANT: THIS IS DATED INFORMATION. When requesting service or replacement parts for your appliance please provide model number and serial number. All parts listed in this manual may be ordered from an authorized dealer.



**Stocked  
at Depot**

ITEM	DESCRIPTION	COMMENTS	PART NUMBER	Stocked at Depot
	Log Assembly		LOGS-TRUE42	Y
1	Log 1		SRV2281-701	
2	Log 2		SRV2281-702	
3	Log 3		SRV2281-703	
4	Log 4		SRV2281-704	
5	Log 5		SRV2281-705	
6	Log 6		SRV2281-706	
7	Log 7		SRV2281-707	
8	Log 8		SRV2281-708	
9	Heat Shield, Header	Qty 2 req	2281-105	
10	Heat Shield, Valve		2281-153	
11	Junction box		4021-013	Y
12	J-Box Bracket		2281-154	
13	Valve Assembly		<b>Refer to Valve Page</b>	
14	Grate Assembly		2281-015	
15	Glass Assembly		GLA-2281	Y
16	Finishing Spacer		2281-113	
17	LED Tub Assembly		2281-017	
18	Inner Glass Frame Assembly		2281-019	
19	Burner Assembly		2281-007	Y
20	Orifice Bracket Flex		2012-008	Y
21	Access Plate		2281-117	

Additional service parts on following page.

8/12

No one builds a better fire

### #22 Stratford Refractory

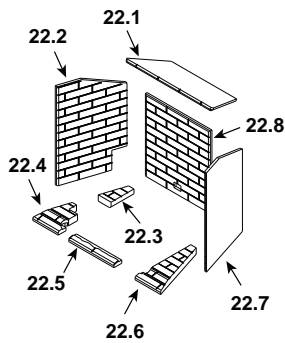

### #23 Herringbone Refractory

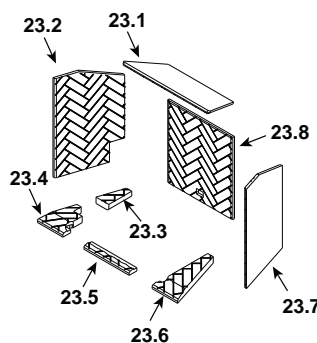

### #24 Castlewood Refractory

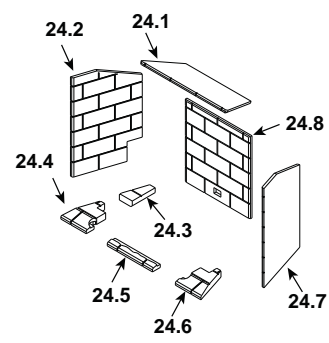

IMPORTANT: THIS IS DATED INFORMATION. When requesting service or replacement parts for your appliance please provide model number and serial number. All parts listed in this manual may be ordered from an authorized dealer.



Stocked at Depot

ITEM	DESCRIPTION	COMMENTS	PART NUMBER	
	Refractory, Stratford	TRUE-42S		
22.1	Refractory, Top		SRV2281-716	
22.2	Refractory, Left		SRV2281-713	
22.3	Refractory, Left Base		SRV2281-718	
22.4	Refractory, Left Base		SRV2281-711	
22.5	Refractory, Front Base		SRV2281-710	
22.6	Refractory, Right Base		SRV2281-712	
22.7	Refractory, Right		SRV2281-714	
22.8	Refractory, Back		SRV2281-715	
	Refractory, Herringbone	TRUE-42H		
23.1	Refractory, Top		SRV2281-726	
23.2	Refractory, Left		SRV2281-723	
23.3	Refractory, Left Base		SRV2281-728	
23.4	Refractory, Left Base		SRV2281-721	
23.5	Refractory, Front Base		SRV2281-720	
23.6	Refractory, Right Base		SRV2281-722	
23.7	Refractory, Right		SRV2281-724	
23.8	Refractory, Back		SRV2281-725	
	Refractory, Castlewood	TRUE-42C		
24.1	Refractory, Top		SRV2281-736	
24.2	Refractory, Left		SRV2281-733	
24.3	Refractory, Left Base		SRV2281-738	
24.4	Refractory, Left Base		SRV2281-731	
24.5	Refractory, Front Base		SRV2281-730	
24.6	Refractory, Right Base		SRV2281-732	
24.7	Refractory, Right		SRV2281-734	
24.8	Refractory, Back		SRV2281-735	

Additional service parts on following page.

### Log Set Assembly

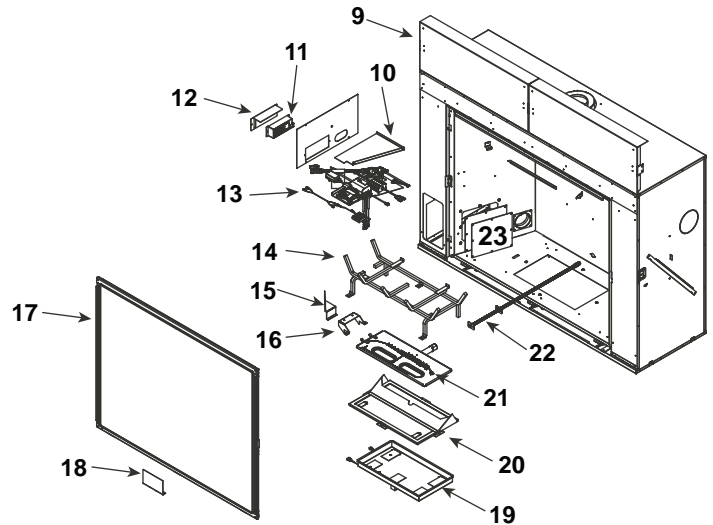
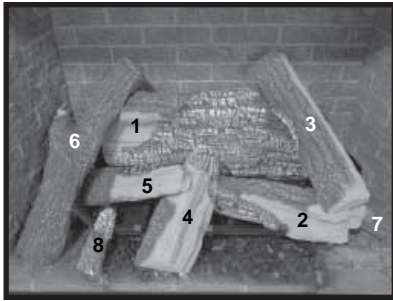

**IMPORTANT: THIS IS DATED INFORMATION.** When requesting service or replacement parts for your appliance please provide model number and serial number. All parts listed in this manual may be ordered from an authorized dealer.



**Stocked  
at Depot**

ITEM	DESCRIPTION	COMMENTS	PART NUMBER	Stocked at Depot
	Log Assembly		LOGS-TRUE50	Y
1	Log 1		SRV2282-701	
2	Log 2		SRV2282-702	
3	Log 3		SRV2282-703	
4	Log 4		SRV2282-704	
5	Log 5		SRV2281-705	
6	Log 6		SRV2282-706	
7	Log 7		SRV2281-707	
8	Log 8		SRV2281-708	
9	Heat Shield, Header	Qty 2 req	2282-105	
10	Heat Shield, Valve		2281-153	
11	Junction box		4021-013	Y
12	J-Box Bracket		2281-154	
13	Valve Assembly		<b>Refer to Valve Page</b>	
14	Grate Assembly		2282-015	
15	Air Deflector		2281-159	
16	Pilot Cover		2282-187	
17	Glass Assembly		GLA-2282	
18	Finishing Spacer		2281-113	
19	LED Tub Assembly		2282-017	Y
20	Inner Glass Frame Assembly		2282-019	Y
21	Burner Assembly NG		2282-007	Y
	Burner Assembly LP		2282-008	Y
22	Orifice Bracket Flex		2282-161	Y
23	Access Plate		2281-117	

Additional service parts on following page.

No one builds a better fire

Beginning Manufacturing Date: June 2012

Ending Manufacturing Date: Active

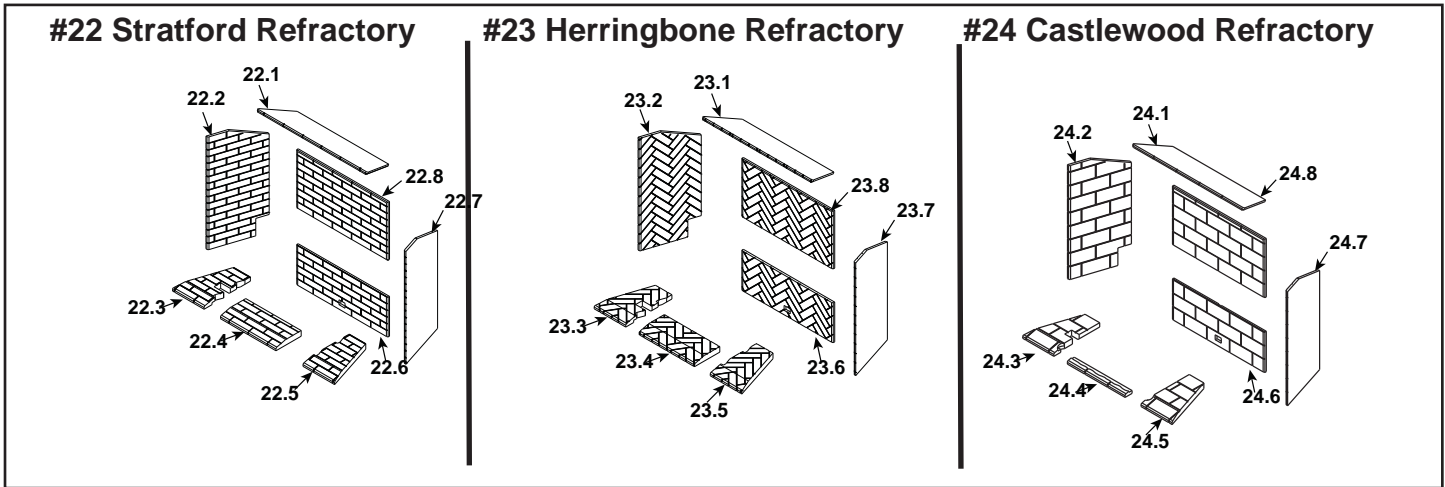

IMPORTANT: THIS IS DATED INFORMATION. When requesting service or replacement parts for your appliance please provide model number and serial number. All parts listed in this manual may be ordered from an authorized dealer.



**Stocked  
at Depot**

ITEM	DESCRIPTION	COMMENTS	PART NUMBER	
	Refractory, Stratford	TRUE-50S		
22.1	Refractory, Top		SRV2282-716	
22.2	Refractory, Left		SRV2282-713	
22.3	Refractory, Left Base		SRV2282-711	
22.4	Refractory, Front Base		SRV2282-710	
22.5	Refractory, Right Base		SRV2282-712	
22.6	Refractory, Back Bottom		SRV2282-715	
22.7	Refractory, Right		SRV2282-714	
22.8	Refractory, Back		SRV2282-717	
	Refractory, Herringbone	TRUE-50H		
23.1	Refractory, Top		SRV2282-726	
23.2	Refractory, Left		SRV2282-723	
23.3	Refractory, Left Base		SRV2282-721	
23.4	Refractory, Front Base		SRV2282-720	
23.5	Refractory, Right Base		SRV2282-722	
23.6	Refractory, Back Bottom		SRV2282-725	
23.7	Refractory, Right		SRV2282-724	
23.8	Refractory, Back		SRV2282-727	
	Refractory, Castlewood	TRUE-50C		
24.1	Refractory, Top		SRV2282-736	
24.2	Refractory, Left		SRV2282-733	
24.3	Refractory, Left Base		SRV2282-731	
24.4	Refractory, Front Base		SRV2282-730	
24.5	Refractory, Right Base		SRV2282-732	
24.6	Refractory, Back Bottom		SRV2282-735	
24.7	Refractory, Right		SRV2282-734	
24.8	Refractory, Back		SRV2282-737	

Additional service parts on following page.

## #13 Valve Assembly

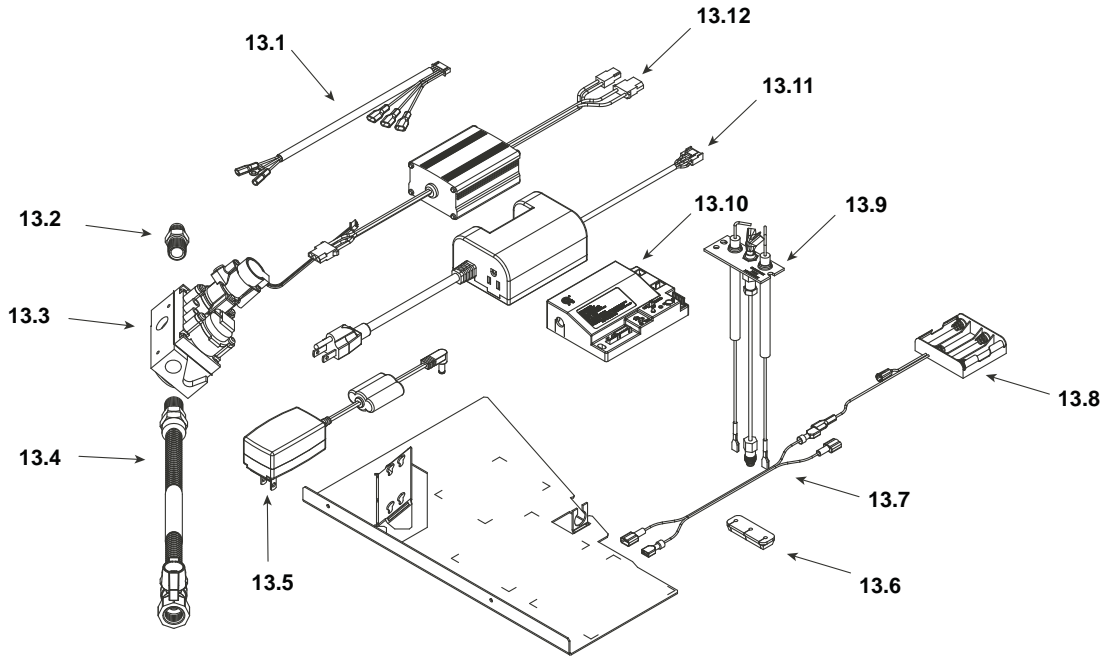

IMPORTANT: THIS IS DATED INFORMATION. When requesting service or replacement parts for your appliance please provide model number and serial number. All parts listed in this manual may be ordered from an authorized dealer.



**Stocked at Depot**

ITEM	DESCRIPTION	COMMENTS	PART NUMBER	Stocked at Depot
13.1	Wire Harness		2166-304	Y
13.2	Male connector	Pkg of 5	303-315/5	Y
13.3	Valve NG		2166-302	Y
	Valve LP		2166-303	Y
13.4	Flex Ball Valve Assembly. 12"		302-320A	Y
13.5	Power Supply		2166-305	Y
13.6	Grommet		2118-420	
13.7	Wire, Battery jumps, 10 in		2281-196	Y
13.8	Battery Pack		2166-323	Y
13.9	Pilot Assembly, NG		2281-012	Y
13.10	Module		2166-307	Y
13.11	Aux 300		2166-335	Y
13.12	Led Controller		2166-336	Y
	Orifice NG (#30C)	TRUE36	582-830	Y
	Orifice LP (#47C)		582-847	Y
	Orifice NG (#26C)	TRUE42	582-826	Y
	Orifice LP (#45C)		582-845	Y
	Orifice NG (#24C)	TRUE50	582-824	Y
	Orifice LP (#43C)		582-843	Y

Additional service parts on following page.

No one builds a better fire

Beginning Manufacturing Date: May 2012

Ending Manufacturing Date: Active

IMPORTANT: THIS IS DATED INFORMATION. When requesting service or replacement parts for your appliance please provide model number and serial number. All parts listed in this manual may be ordered from an authorized dealer.



**Stocked  
at Depot**

ITEM	DESCRIPTION	COMMENTS	PART NUMBER	
	Air Shutter Burner Tube		2052-157	
	Exhaust Restrictor		530-299	
	Gasket Assembly		2281-080	
	Glass Clip Tool		2281-375	
	Glass Latch Assembly	Qty 2 req	2146-413	Y
	Glass Latch Assembly	True-36 (Qty 3 req)	2155-045	Y
		True-42 & 50 (Qty 4 req)		
	Kapton Lens, Light Orange	Qty 2 req	2166-171	Y
	Kapton Lens, Dark Orange	Qty 3 req	2166-184	Y
	Mineral Wool		050-721	
	Nut 1/4-20 Hex Insert		7000-236	
	Non-Comb Assembly	True-36	2280-040	
		True-42	2281-040	
		True-50	2282-040	
	Refractory Tab	Qty 2 req	2281-114	
	Relief Door Assembly		7011-011	
	Remote RC300		2166-330	Y
	Screws	2 Pkgs of 12	2062-110-12/2	Y
	Teco Silica, 2.5 Lbs		2281-790	
	Teco Silica, 5 Lbs	True-36 (1 per)	700-790	
		True-42 & 50 (2 per)		
	Top Refractory Support		2281-190	
	Vermiculite Embers		MYSTIC-EMBERS	
	Conversion Kit NG	TRUE36	NGK-TRUE36	Y
	Conversion Kit LP		LPK-TRUE36	Y
	Conversion Kit NG	TRUE42	NGK-TRUE42	Y
	Conversion Kit LP		LPK-TRUE42	Y
	Conversion Kit NG	TRUE50	NGK-TRUE50	Y
	Conversion Kit LP		LPK-TRUE50	Y
	Pilot Orifice NG		593-528	Y
	Pilot Orifice LP		593-527	Y
	Regulator NG		NGK-DXV-50	Y
	Regulator LP		LPK-DXV-50	Y

**D. Contact Information**



No one builds a better fire

Heat & Glo, a brand of Hearth & Home Technologies Inc.  
7571 215<sup>th</sup> Street West, Lakeville, MN 55044  
www.heatnglo.com

Please contact your Heat & Glo dealer with any questions or concerns.  
For the location of your nearest Heat & Glo dealer,  
please visit [www.heatnglo.com](http://www.heatnglo.com).

**- NOTES -**

---

---

---

---

---

---

---



---

---

---

---

---

<b>NOTICE</b>		
	<b>DO NOT DISCARD THIS MANUAL</b>	
<ul style="list-style-type: none"><li>• Important operating and maintenance instructions included.</li></ul>	<ul style="list-style-type: none"><li>• Read, understand and follow these instructions for safe installation and operation.</li></ul>	<ul style="list-style-type: none"><li>• Leave this manual with party responsible for use and operation.</li></ul>

This product may be covered by one or more of the following patents: (United States) 5328356, 5601073, 5613487, 5647340, 5890485, 5941237, 5947112, 5996575, 6006743, 6019099, 6053165, 6145502, 6170481, 6374822, 6484712, 6601579, 6769426, 6863064, 7077122, 7098269, 7258116, 7470729 or other U.S. and foreign patents pending.

2000-945